

MVDA-80 series

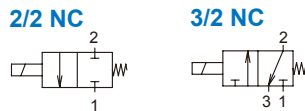

DIRECT ACTING TYPE COMPACT SOLENOID VALVE

Mindman

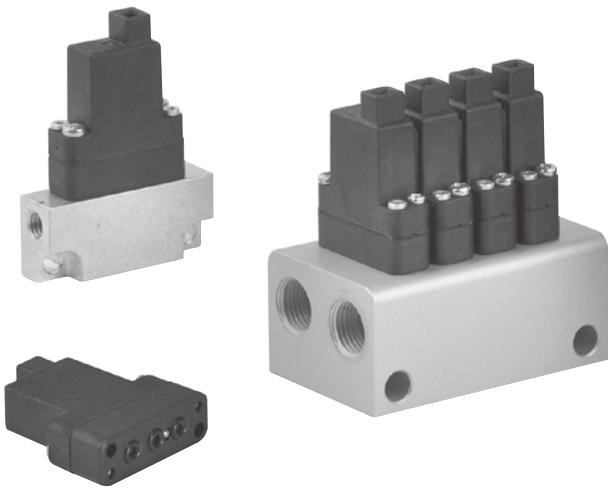

Features

- Response time < 1ms.
- Product life: 500 million switching cycles.
- Ultra response frequency: 500Hz.

Order example of valve

MVDA – 80 – 3E1 – NC – DC24 – C – A – M3

Specification

Model	2E1-KK-A	3E1-KK	3E1-DC24	3E1-DC12
No. of port	2	3		
No. of position	2			
Medium	Dry air, inert gas			
Operating pressure range	0~1.2 MPa	0~0.8 MPa		
Flow rate (N l/min)	25 ± 10%	28 ± 10%		
Response time (ms)	ON	0.7 ± 0.5	2.0 ± 0.5	2.0 ± 0.5
	OFF	1 ± 0.2	0.6 ± 0.2	0.5 ± 0.2
Operating fluid temp.	-10~+50°C			
Ambient temperature	-10~+50°C			
Storage temperature	-10~+50°C			
Voltage	Speed-up: DC24V, Hold: DC5V		DC24V	DC12V
	Power consumption	0.8 W (Hold)	0.5 W (Hold)	1.2 W
Filter element	40 µm			
Lubrication	No required			
Max. operating frequency	500 Hz (at 250Hz with driver board)		200 Hz	280 Hz
	IP protection class	IP52		
Weight	8 g			

* 3E1-DC12 is make to order.

Port	Voltage	Wire	Pressure
2E1-NC: 2 way (2 port)	KK: DC24V / DC5V (Speed-up in tension) Speed-up: DC24V, hold: DC5V	C: Without driver board S: With driver board (24/5V Signal converter)	A: High pressure (0~1.2 MPa)
3E1-NC: 3 way (3 port)	DC12: DC12V DC24: DC24V KK: DC24V / DC5V (Speed-up in tension) Speed-up: DC24V, hold: DC5V	C: Without driver board S: With driver board (24/5V Signal converter)	Blank: General pressure (0~0.8 MPa)

SYMBOL OF ASSEMBLY

B1: Assembly (Base+Valve)

M□: 2,3,4...Manifold number Assembly (Manifold+Valve)

Order example of base

MVDA – 80 – 3B1

MODEL

BASE

2B: 2 port base
3B: 3 port base

KK type electrical control

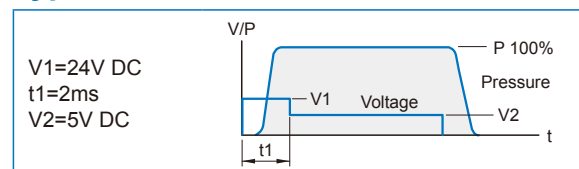

Order example of manifold

MVDA – 80 – 3M2

MODEL

MANIFOLD

MANIFOLD NUMBER
2, 3, 4...

2M: 2 port
3M: 3 port

The wire with driver board (S) dimensions

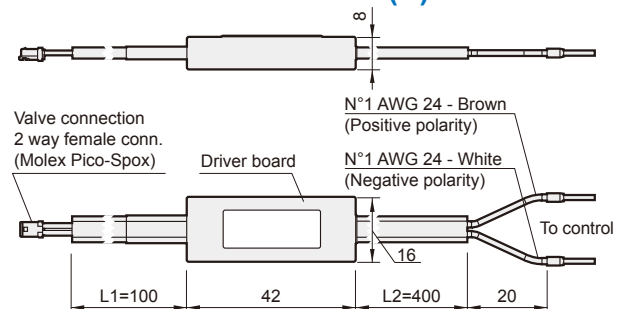

MVDA-80 Dimensions / Base / Manifold



DIRECT ACTING TYPE COMPACT SOLENOID VALVE

mindman

MVDA-80-*E1

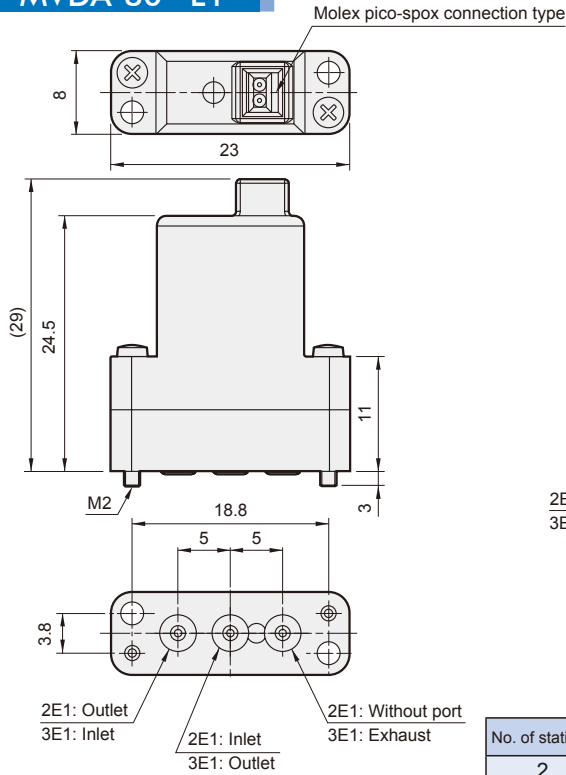

MVDA-80-*B1

Base

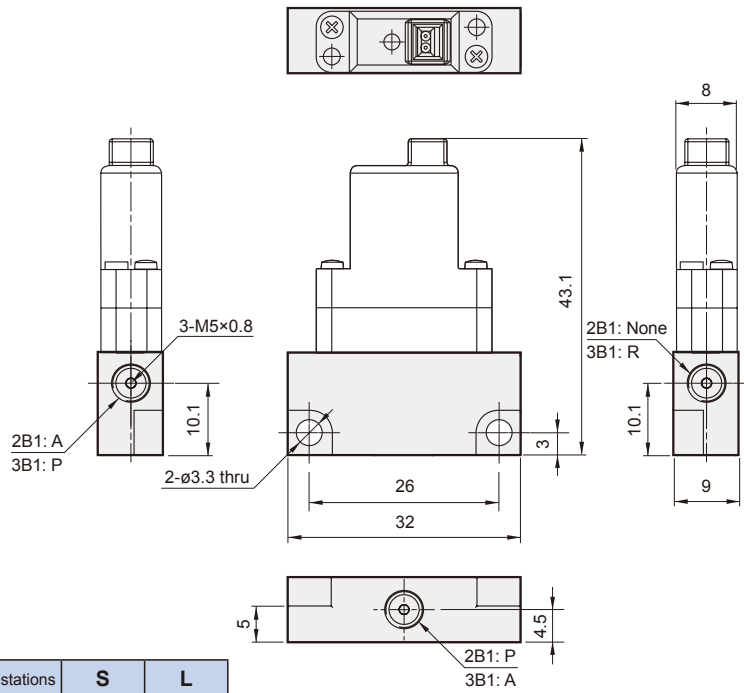

MVDA-80-*M*

Manifold

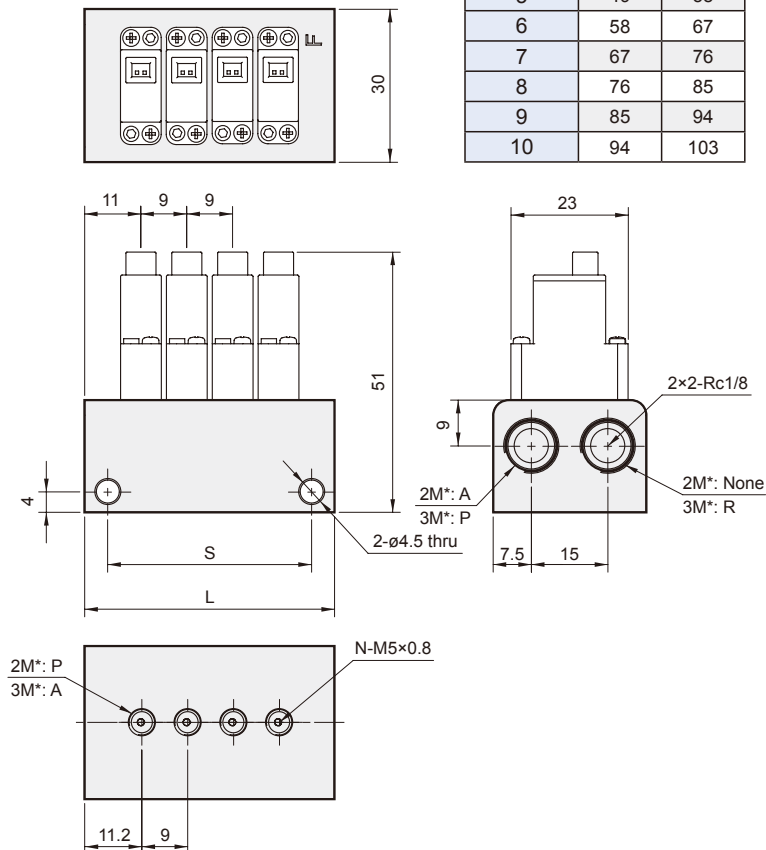

No. of stations	S	L
2	22	31
3	31	40
4	40	49
5	49	58
6	58	67
7	67	76
8	76	85
9	85	94
10	94	103

Flow features

MVDA-80-2E1

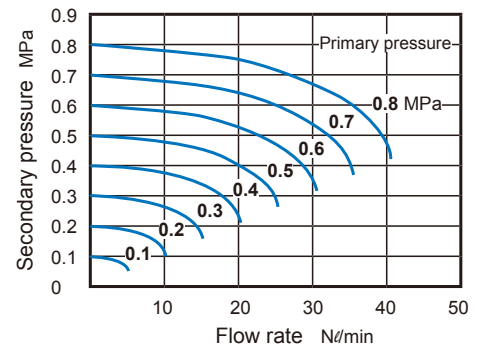

MVDA-80-3E1

