

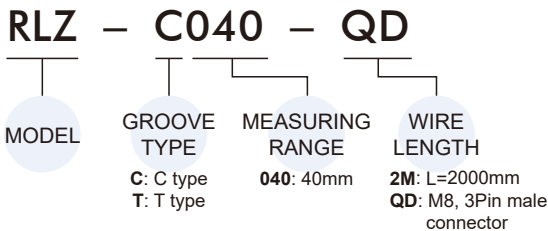

Order example



Applicable

For the measurement of dimensions.

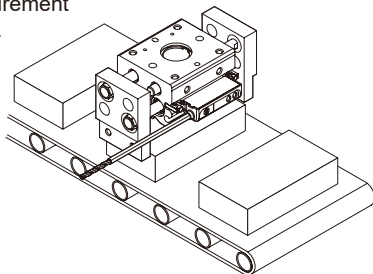

Used to check machined holes.

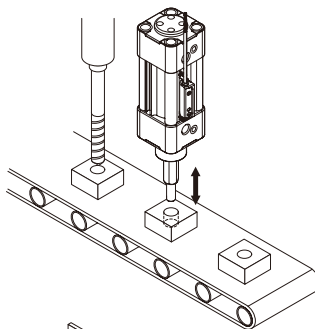

For long/short side detection.

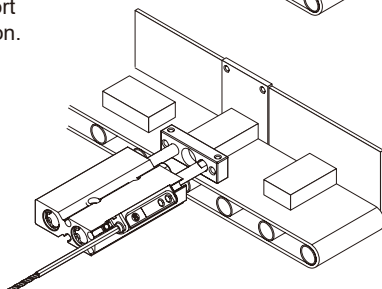

Features

- Repeatability ± 0.01 mm
- Analog output invertible (0~10V \leftrightarrow 10~0V)(4~20mA \leftrightarrow 20~4mA)
- Sampling time ≤ 0.3 ms
- Voltage / current output switchable
- Freely set measuring range

Specification

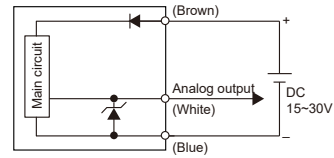
Model	RLZ
Measuring range	40 \pm 1 mm
Power supply voltage	15 ~ 30 V DC, Ripple (P-P) ≤ 10 %
Current consumption	≤ 15 mA (with no load)
Displacement resolution *1	0.001 mm
Linearity error *1	± 0.2 mm @ 25 °C
Repeatability *1	± 0.01 mm @ 25 °C
Sampling time	≤ 0.3 ms
Analog voltage output *2	Voltage Output : 0 ~ 10 V Min. Load Impedance : 2 K Ω Linearity : ± 0.05 % F.S. @ 25 °C Sensitivity : 0.25 mV/ μ m
Analog current output *2	Current Output : 4 ~ 20 mA Max. Load Impedance : 500 Ω Linearity : ± 0.05 % F.S. @ 25 °C Sensitivity : 0.4 μ A/ μ m
Magnetic field strength*1,3	20 ~ 200 Gauss
Enclosure	IP69 IEC 60529
Ambient temp. Range	Operation : 0 ~ 50 °C, Storage : -10 ~ 60 °C (No condensation or freezing)
Ambient humidity range	Operation / Storage : 35 ~ 85 % RH (No condensation)
Withstand voltage	1000 V AC in 1-min (between case and lead wire)
Insulation resistance	≥ 50 M Ω (at 500 V DC, between case and lead wire)
Shock *4	30 G
Vibration *5	10 G
Lead wire	$\phi 2.9$ PUR - 26 AWG (0.15mm ²) - 3 cores
Protection circuit	Power source reverse polarity, Surge suppression
Weight (with 2M lead wire)	Approx. 33 g (C type), Approx. 37 g (T type)
Connect diagram	

*1. Measuring standard target : $\phi 15.5 \times \phi 8 \times 5t$ (The movement of anisotropy rubber magnet and piston are from same direction.)

*2. Only one of analog output can be selected while setting.

*3. The difference of magnetism, environment, and interference of magnetic field can cause the deviation of measurement.

*4. Sin wave / X , Y , Z 3 directions / 3 times each direction / 11 ms each time.

*5. Double amplitude 1.5 mm or 10 G / 10 Hz ~ 55 Hz ~ 10 Hz (Sweep 1 min) / X, Y, Z 3 directions / 2 hours each time.

*6. Caution for safety please refer to page10-3.

⚠ Caution

- * The repeatability of sensor will be affected by the operational condition and environment.
- * Avoid piston and magnet of cylinder spin to cause inaccuracy.
- * To ensure good repeatability, models marked with ● require special specification orders.

● Standard cylinder
 ● Special cylinder

	Model	Stroke Tube I.D.	5	10	15	20	25	30	40	50	60	80	100	150	200	250	300	400	500			
Mini	MCMJP (C type)	10					●	●														
		16					●	●	●													
Guide cylinder	MCGI (T type)	20,25				●	●	●	●	●	●	●	●									
		32,40			●	●	●	●	●	●	●	●	●	●	●	●						
		50			●	●	●	●	●	●	●	●	●	●	●	●	●	●				
	63,80,100		●	●	●	●	●	●	●	●	●	●	●	●	●	●	●					
	MCDJ (C type)	6				●		●	●	●												
10			●		●		●	●	●													

	Model	Tube I.D. Spec.	6	8	10	12	16	20	25	32	40	50	63	80	100	125	160	200	300				
Cylinder	MCKQI2 (T type)									●	●												
	MGTB/U/X *1 (T type)									●	●												
Rotary actuator	MCRJ-S (C type)	90°																					
		180°	●	●																			
	MCRQ (C type)	90°				●	●	●	●	●													
		180°					●	●	●	●													
Gripper	MCHD (C type) *2	Short				●	●	●															
		Medium		●*3		●	●	●															
		Long		●		●	●	●															
	MCHU (C type)					●	●	●															
	MCHS (C type)																	●	●	●			
	MCHX (C type)				●		●	●	●	●	●	●											
MCHY (C type)				●		●	●	●	●														

*1. The cylinders for MGTB/U/X are MCKQI2.

*2. MCHD must use single magnet specification.

*3. Please install the sensor in the middle of MCHD-8 medium stroke (as shown in Figure 2).

*4. The built-in magnets must be glued except *2.

*5. RLZ is also applicable to the models marked with ● in standard specification if good repeatability is not required. (except MCHD and MCRQ-12 series)

*6. Please contact us if required models not found in the table.

Order example of special cylinder

Standard model no. — XZ1

Suitable for RLZ series
 * Special cylinder, please contact us

Installation

Move the sensor to the required position, then tighten the screw by hexagon wrench 2.0 mm with tightening torque 0.2 ~ 0.4 Nm (as shown in Figure 1).

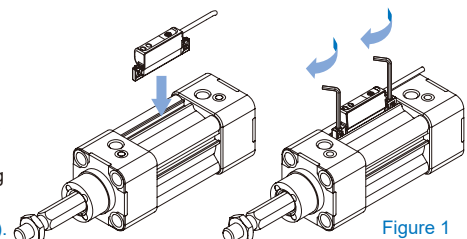

⚠ Precautions (Read before installing)

- Be sure to tighten within the recommended tightening torque when mounting the actuator position sensor.
- According to the installation condition, the cylinder may not operate even when mounted appropriately. If the sensor doesn't work, try following solutions: 1. Restart the power. 2. Operate the cylinder for several times.
- Turn off power before connecting wiring. Wrong wiring or short circuit will damage and / or cause malfunction.

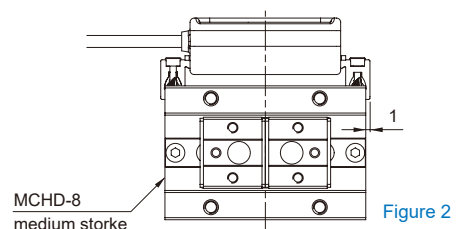

Wiring of the QD

- 3 wire QD wiring

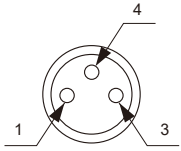

- 1 Brown(+)
- 3 Blue(-)
- 4 White (analog output)

Analog output function

- Analog voltage / current output can be switched.
- Analog output can be inverted.

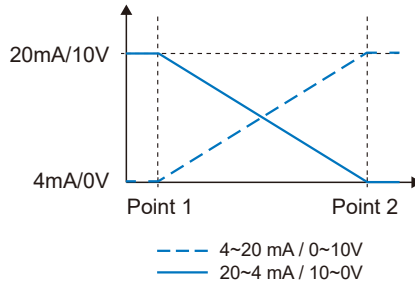

Information indicator LED color description

Please ensure that the required measurement range of the cylinder is within the measurement range of RLZ.

Default setting



Resetting

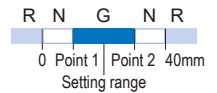

Description	
G (Green)	Within the setting range
N (Non)	Within the measuring range, but outside the setting range.
R (Red)	Outside the measuring range

Dimensions

RLZ-C

C type

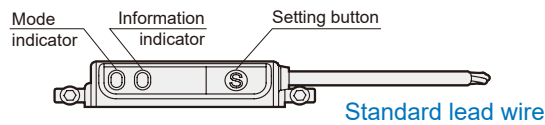

Standard lead wire

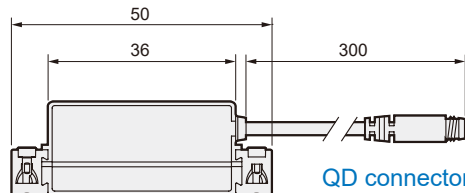
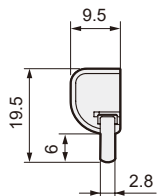

QD connector

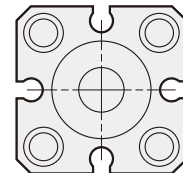
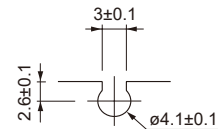

RLZ-T

T type

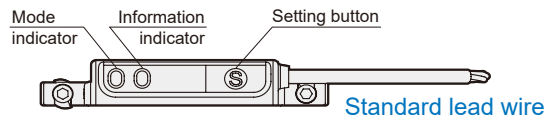

Standard lead wire

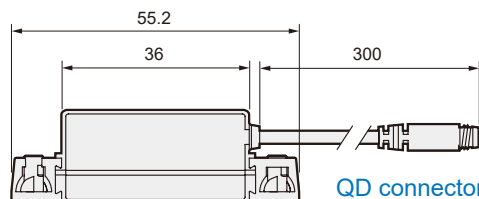
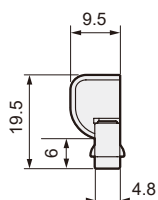

QD connector

