

Order example of cylinder

MCKD – 50 – 120 □ – □ – RNKD

MODEL

TUBE I.D.

50
63

PORT THREAD

Blank: Rc thread
G: G thread
NPT: NPT thread

SENSOR SWITCH

Blank: Without
RNKD: NPN
RPKD: PNP

Available release angle range (*1)

15: 15°
30: 30°
45: 45°
60: 60°
75: 75°
90: 90°
105: 105°
120: 120°
135: 135° (*2)

HANDLE

Blank: Non-handle
L: Left side
R: Right side

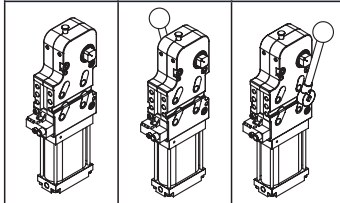

*1. Please check dimensions page for the clamping angle of reverse mounting type.

*2. Only available for non-handle type.

*3. The order number of cylinder does not contain the arm. The order number of arm is shown below.

Order example of clamping arm

AM – MCKD – 50 – 15 R S

MODEL

TUBE I.D.

50
63

PORT SIZE

S: D1: ø6, D2: ø9
B: D1: ø8, D2: ø10.2

OFFSET

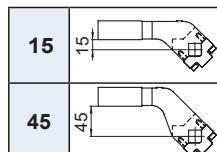

MOUNTING POSITION

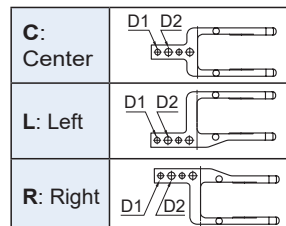

Features

- Oval piston design for space saving.
- Clamping arm angle is adjustable via adjusting bolt with ease.
- 12 types of clamping arm for various usage.
- 15° minimum release angle for lowering clamping time.
- Welding slag and magnetic field proof sensor available.
- Cylinder remains clamping position with self-locking mechanism even if there is no air input.

Specification

Model	MCKD	
Acting type	Double acting	
Tube I.D. (mm)	50	63
Port size	Rc1/8	Rc1/4
Release angle range	15°, 30°, 45°, 60°, 75°, 90°, 105°, 120°, 135°	
Medium	Filted air	
Operating pressure range	0.3~0.8 MPa	
Proof pressure	1.2 MPa	
Ambient temperature	-10~+60°C (No freezing)	
Cushion	Cushion pad (*1)	
Min. operating time	At least 1.0 second to clamp and unclamp	
Sensor switch	RNKD (Please refer to page 5-15)	
Weight	Cylinder (*1)	2800 g 3400 g
	Arm	15 type: 1050 g 15 type: 1250 g 45 type: 1150 g 45 type: 1400 g

*1. Need to install speed controller. Please refer to page 8-15~17 (Vol.1).

*2. The cylinder weight includes handle.

Installation of sensor switch

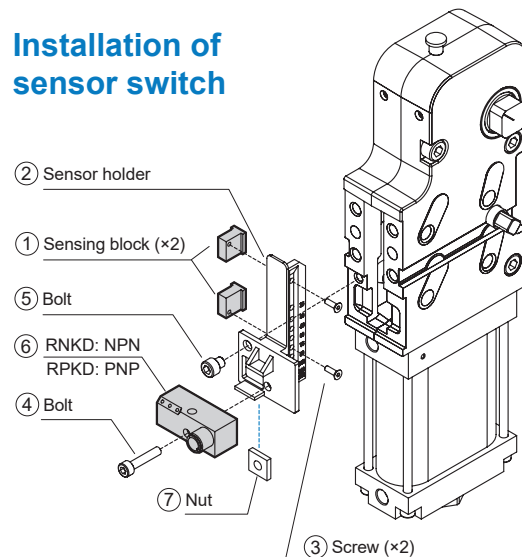

Installation step

1. Use ③ to mount ① on ②.
2. Use ④ and ⑦ to mount ⑥ on ②.
3. Use ⑤ to mount ② on cylinder.

Sensor set

Order number	I/O type
RZ-MCKD-N	NPN
RZ-MCKD-P	PNP

* Accessory kits include

① ③ ④ ⑥ ⑦

POWERFUL CLAMP CYLINDER

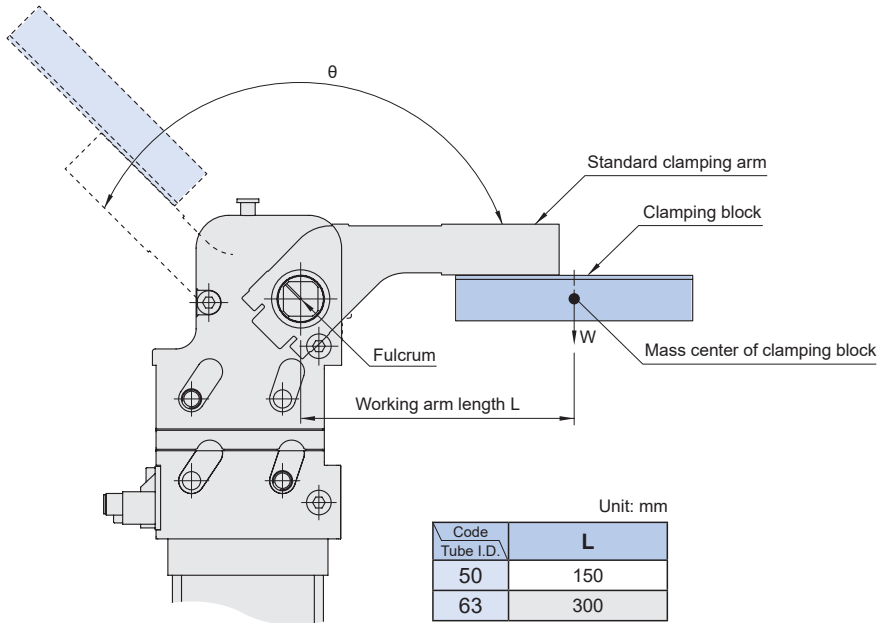

Force & Working arm length chart

- The length of the working arm length "L" has to be the value given below or less.
- Please use the standard clamping arm in the catalog with your clamping block.

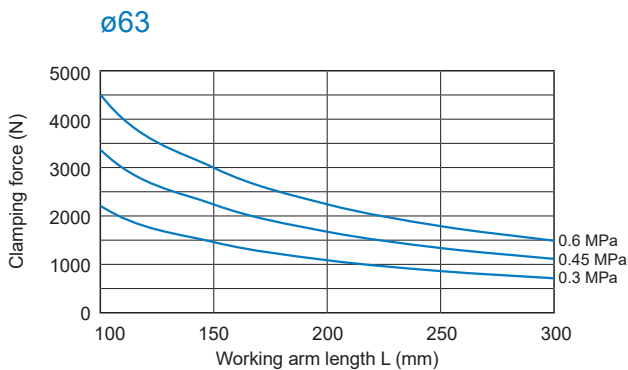
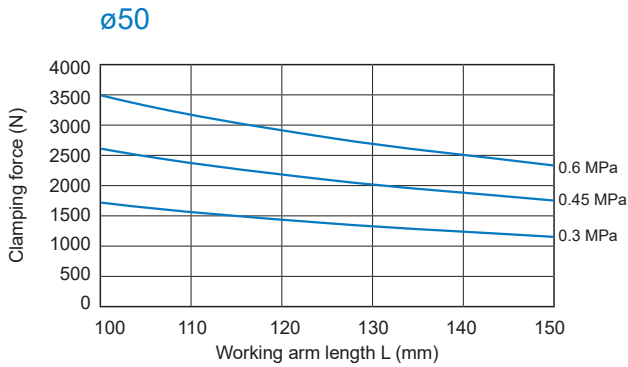

Available clamp block weight & Clamp angle chart

- The arm opening angle is inversely proportional to available clamping block weight.
- Only the weight of clamping block has to be considered.

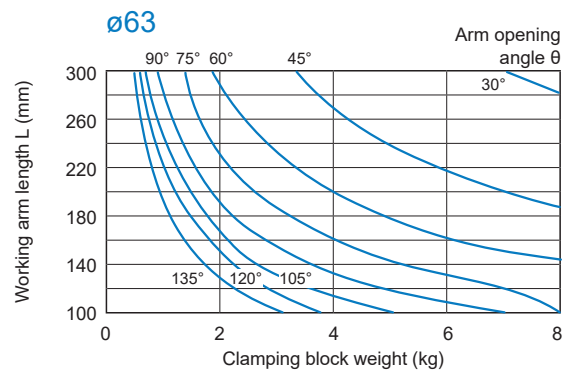
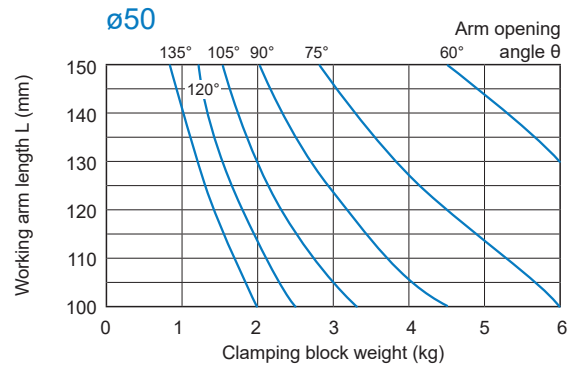

Common precautions

- ① Use F.R.L. unit with 5 μm element filter.
- ② Clean the power clamp cylinder with air blow before piping.
- ③ Use standard arm in Mindman catalog only.
- ④ Use two speed controller at both ports. Clamping and releasing speed both must be more than 1 second.

Mounting guide

① Basic clamping method

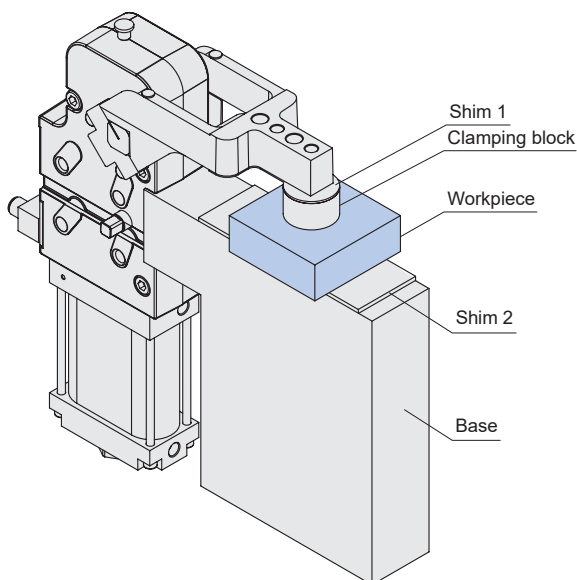

② Mounting sequence

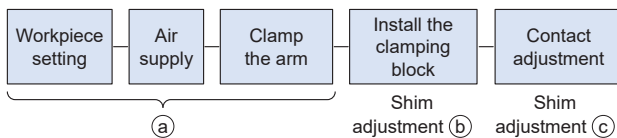

③ Details

- (a) Place the workpiece on the base. Clamp the arm to the end of stroke without installing the clamping block.
- (b) Place the clamping block between arm and workpiece. Find suitable shim to insert into the gap between arm and clamping block. Make the gap is nearly 0. Theoretically there is no clamping force.
- (c) Check the clamping force curve and find the needed clamping force and operation pressure. Insert a second shim with corresponding thickness between workpiece and base and adjust the pressure. The setting is done. (There is a 10% tolerance in our clamping force chart due to the tolerance of each part.)
- (d) Release the compressed air and check the self-locking function is working or not before usage.

Clamping force and mounting details

- ① The pictures below show the clamping force curve. There is always a peak for highest clamping force in every curve. When the thickness of inserted second shim exceeds the peak of the force curve, the self-locking mechanism doesn't work.
- ② The arm length is defined as picture below.

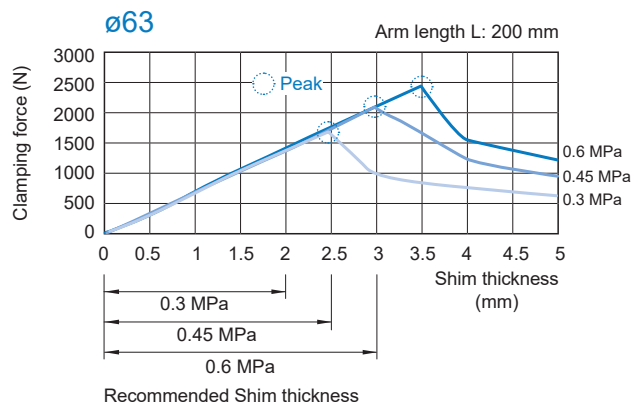
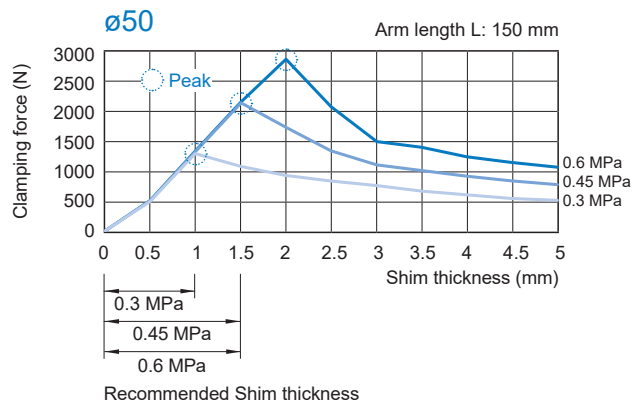
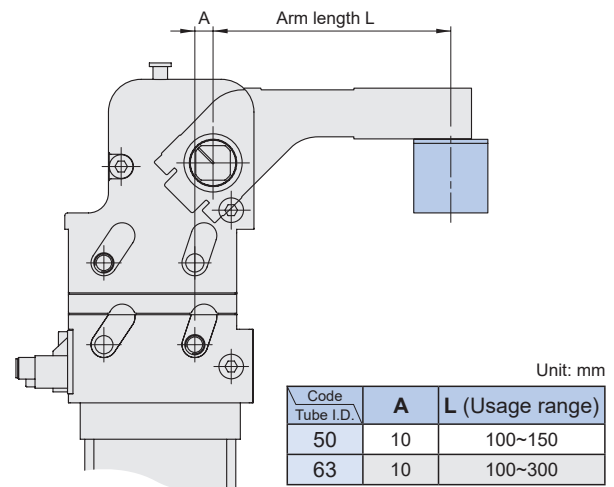

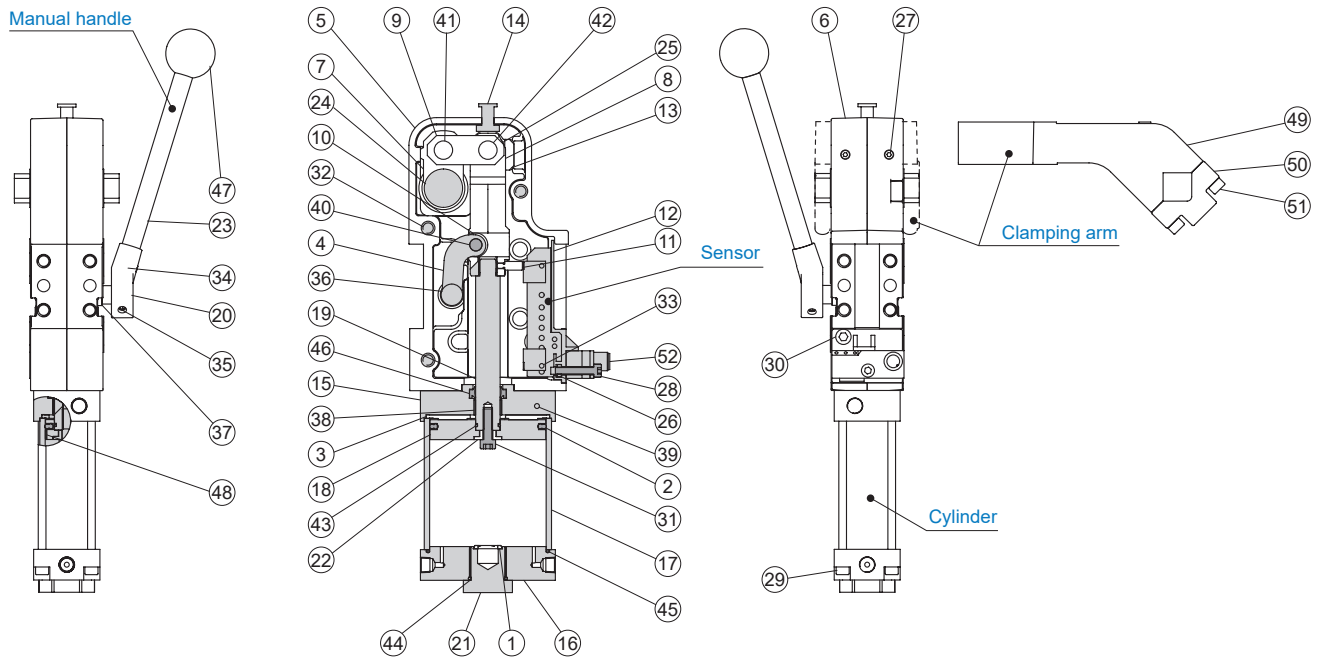

Material

N: Without handle, L: Left side handle, R: Right side handle

No.	Part name	Material	Q'y	
			N	L,R
1	Cushion pad	TPU	1	
2	Piston ring	HNBR	1	
3	Cushion pad	TPU	1	
4	Manual shaft	Carbon steel	0	1
5	Right side cover	Aluminum alloy	1	
6	Left side cover	Aluminum alloy	1	
7	Drive shaft	Carbon steel	1	
8	Y connector	Carbon steel	1	
9	Connecting bar	Carbon steel	1	
10	Wheel	Carbon steel	0	2
11	Sensing stick	Carbon steel	1	
12	Sensor holder	Plastic	1	
13	Stopper	Carbon steel	2	
14	Bump pin	Carbon steel	1	
15	Rod cover	Aluminum alloy	1	
16	End cover	Aluminum alloy	1	
17	Cylinder	Aluminum alloy	1	
18	Piston	Aluminum alloy	1	
19	Piston rod	Stainless steel	1	
20	Handle holder	Carbon steel	0	1
21	Adj. bolt	Iron	1	
22	Locking rod	Carbon steel	1	
23	Rod	Stainless steel	0	1
24	Needle bearing	-	2	
25	Needle bearing	-	2	
26	Square nut	Carbon steel	1	

No.	Part name	Material	Q'y	
			N	L,R
27	Bolt	Carbon steel	2	
28	Bolt	Carbon steel	1	
29	Bolt	Carbon steel	4	
30	Bolt	Carbon steel	1	
31	Bolt	Carbon steel	1	
32	Bolt	Carbon steel	3	
33	Bolt	Carbon steel	2	
34	Screw	Carbon steel	0	1
35	Screw	Carbon steel	0	2
36	Bush	Bearing alloy	0	1
37	Bush	Bearing alloy	0	1
38	Bush	Bearing alloy	1	
39	Ball	Stainless steel	1	
40	Pin	Bearing steel	0	1
41	Pin	Bearing steel	1	
42	Pin	Bearing steel	1	
43	O-ring	NBR	1	
44	O-ring	NBR	1	
45	O-ring	NBR	1	
46	Rod packing	NBR	1	
47	Ball	Bakelite	0	1
48	Wear ring plate	Resin	2	
49	Clamping arm	Carbon steel	1	
50	Arm holder	Carbon steel	2	
51	Bolt	Carbon steel	4	
52	Sensor switch	-	1	

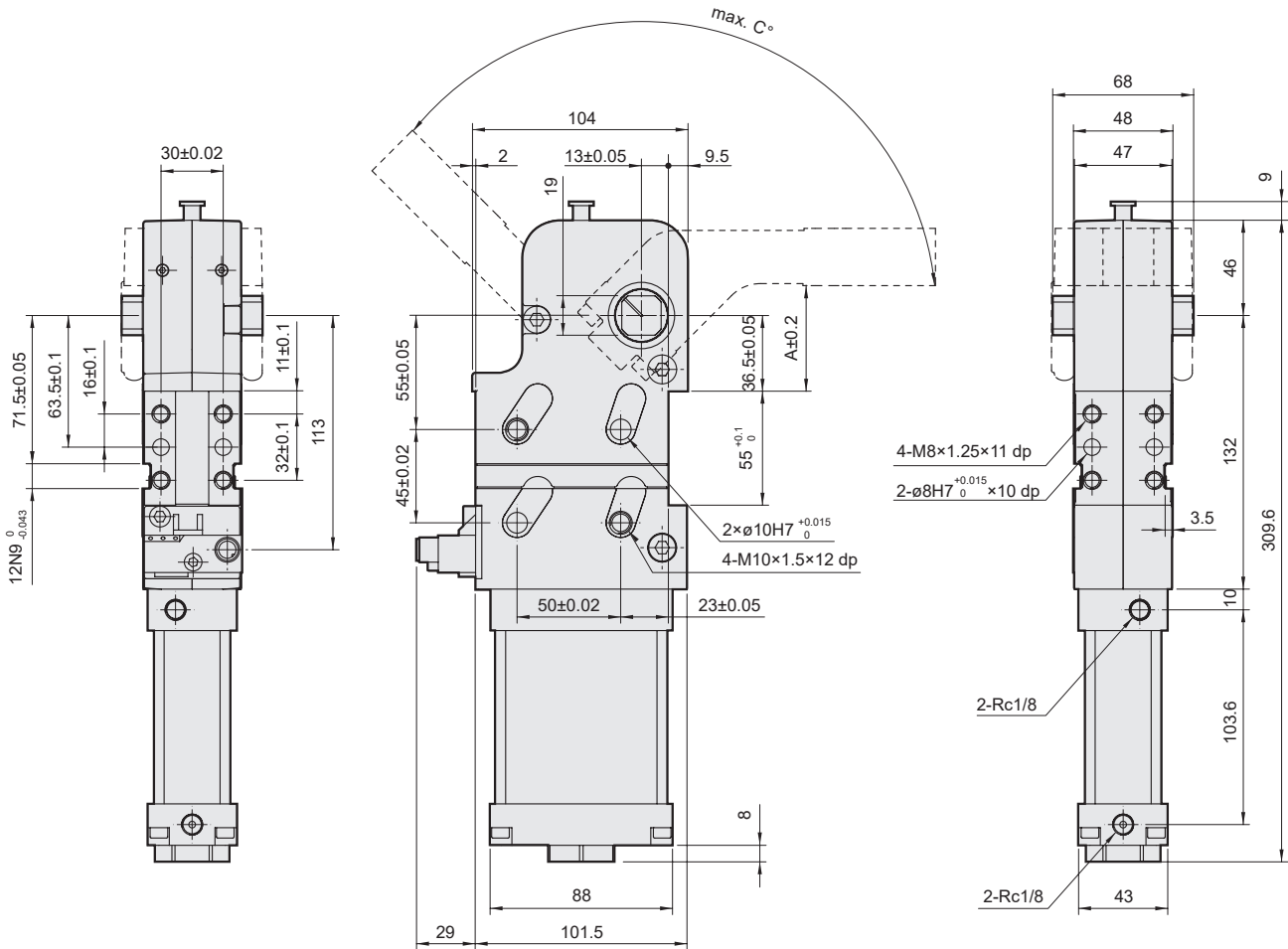

Code	Offset	A	B	C	
				Standard	Handle
50	15	51.5	30	135	120
	45	81.5	60	135	120

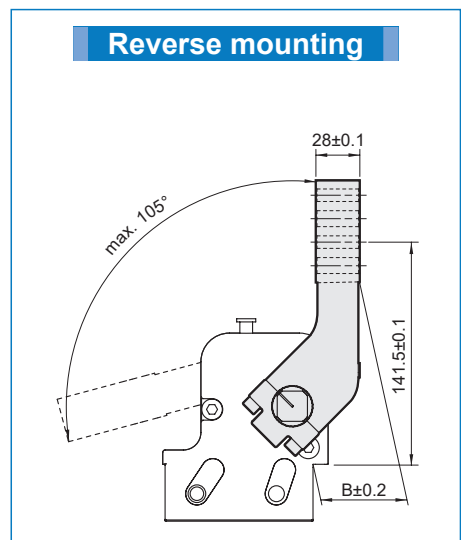
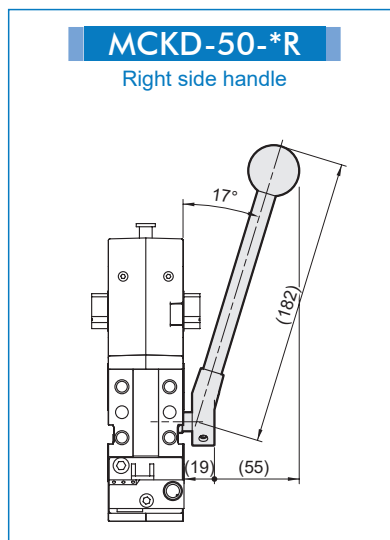
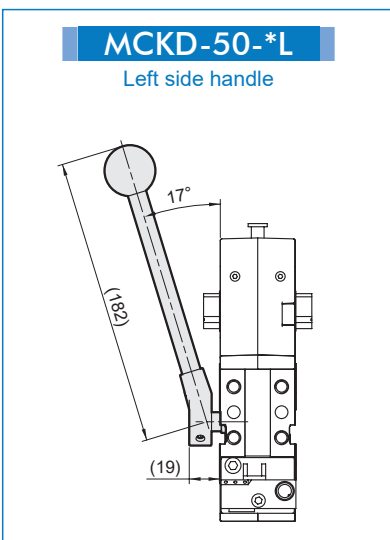

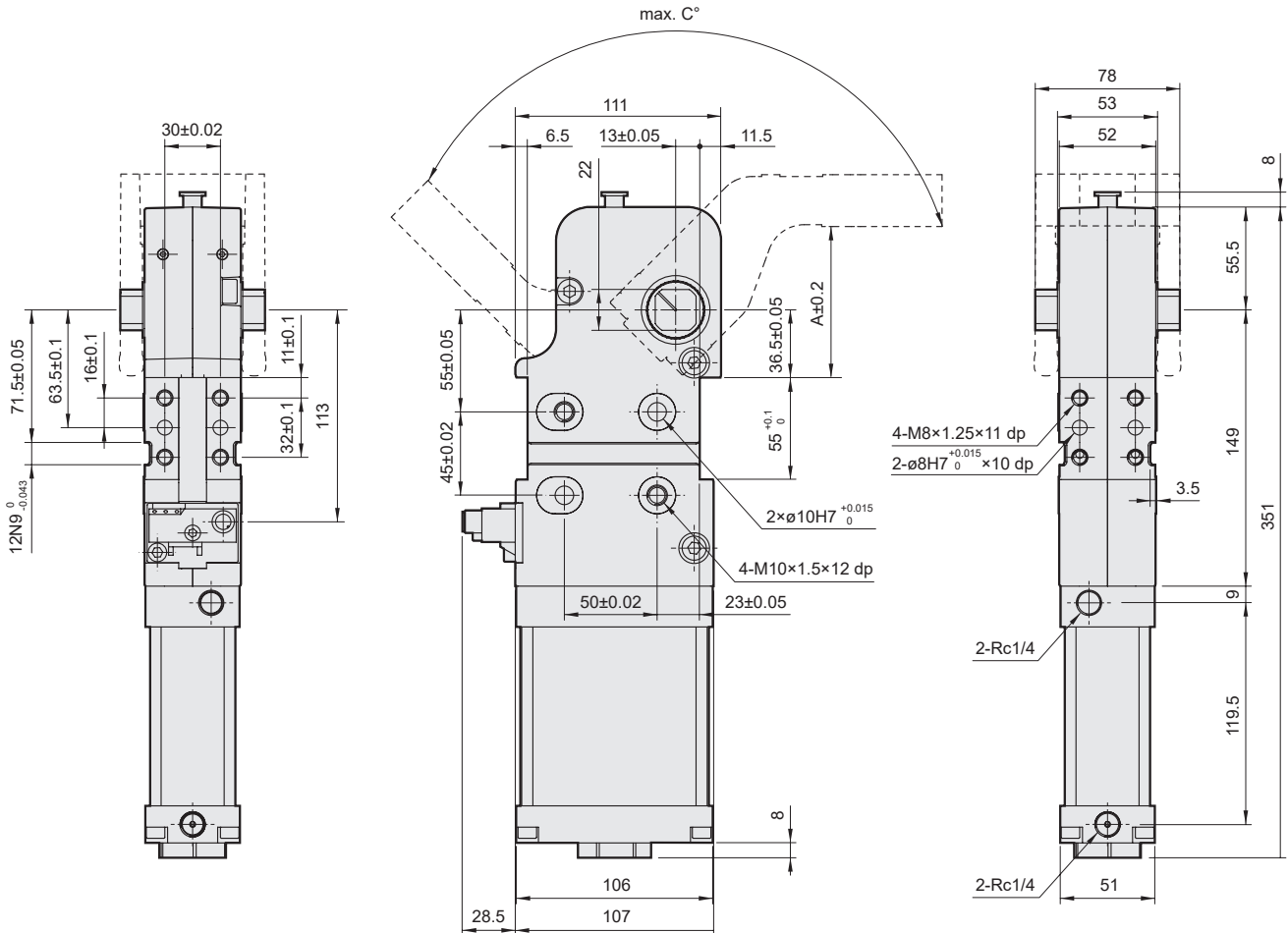

Code Tube I.D.	Offset	A	B	C	
				Standard	Handle
63	15	51.5	30	135	120
	45	81.5	60	135	120

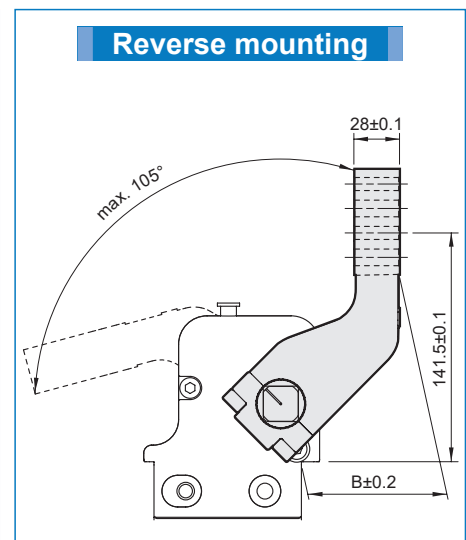
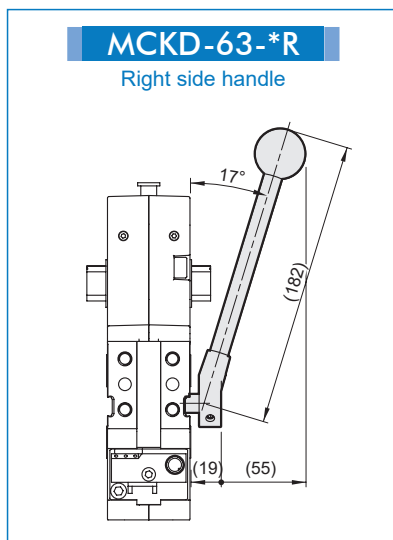
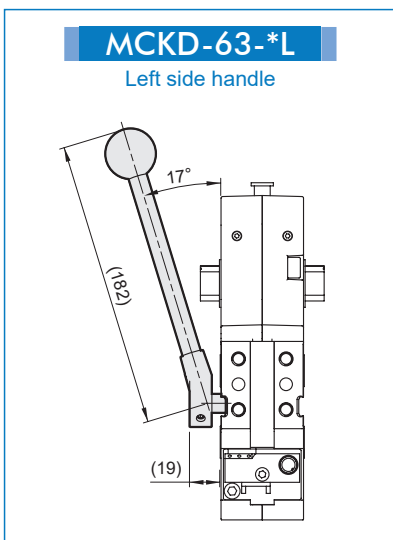

15 type

45 type

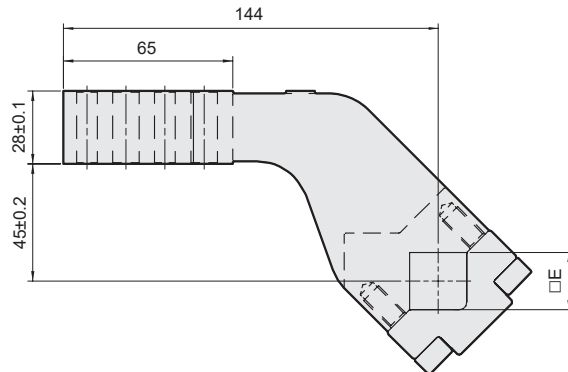
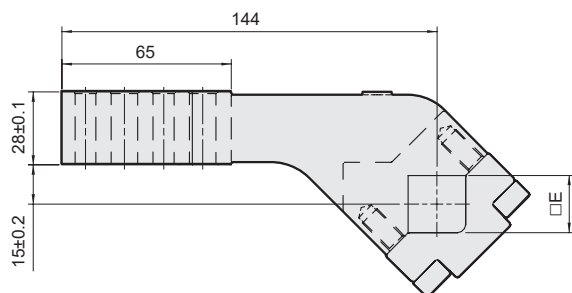
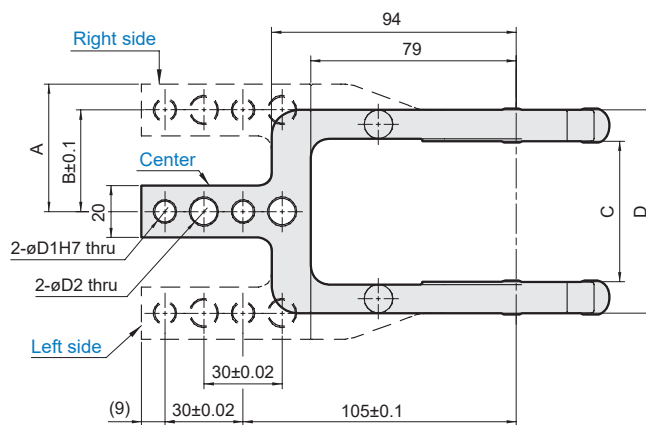
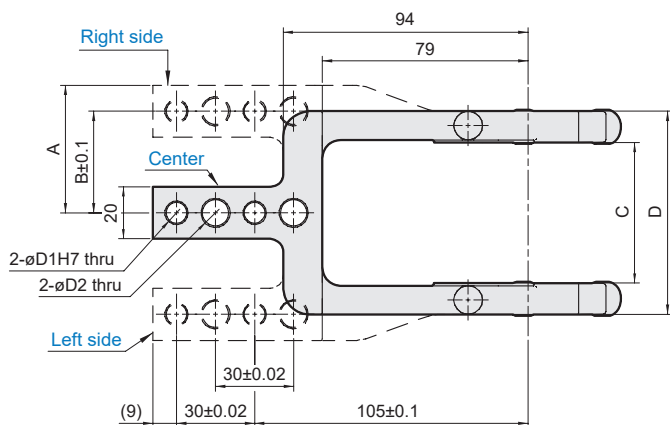

Code Tube I.D.	A	B	C	D	D1		D2		E
					S*	B*	S*	B*	
50	44	34	48	68	6	8	9	10.2	19
63	47	37	54	78	6	8	9	10.2	22

* S, B was the port size code of clamping arm.