



### Features

- Increase the primary pressure in the air line up to twice.
- Air-only operation requires no power supply, reduces heat generation, and allows easy installation.

### Specification

Model	MVBAT10	MVBAT20
Port size	Rc3/8	
Medium	Air	
Pressure increase rate	Twice	
Tank internal capacity	10 L	20 L
Operating pressure range	0.2~1 MPa	
Supply pressure range	0.1~1 MPa	
Proof pressure	1.5 MPa	
Max. flow rate (*)	1000 ℓ/min	
Ambient temperature	+2~+50°C	
Installation	Horizontal	
Lubrication	Grease (Non-lube)	
Attachment	Pressure gauge (PG-25)	
Option	Air units (MAFRF401AD-10A), Silencer (MSLT-03), Drain valve	
Weight	12 kg	20 kg

### Order example

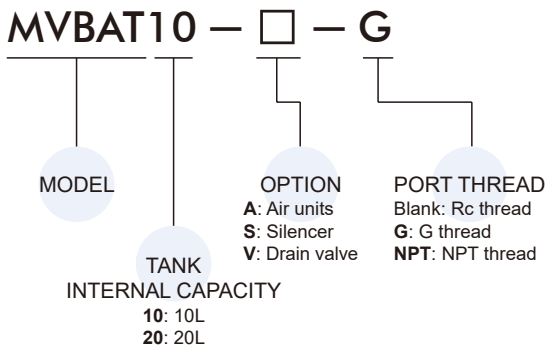

\* Max. flow rate at In=Out=0.5 MPa.

### Caution

- If the outlet capacity is undersized, pulsation may occur.
- Make sure to install a mist separator (0.3μm) at the inlet side of the booster regulator.
- The booster regulator has a sliding part inside, and it generates dust. Also, install a cleaning device such as an air filter or a mist separator on the outlet side as necessary.
- Provide a dedicated pipe to release the exhaust air from each booster regulator. If exhaust air is converged into a pipe, the back pressure that is created could cause improper operation.
- Depending on the necessity, install a silencer on the exhaust port of the booster regulator to reduce the exhaustion sound.
- Sufficient space for maintenance and inspection is suggested.

### Dimensions ( ) for MVBAT20

