

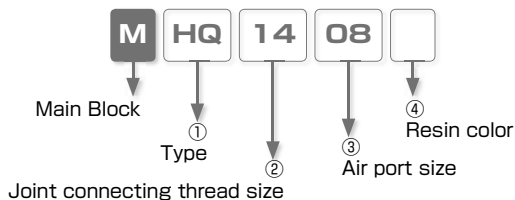

Concentrated Branching Joint for Assembly Main Block Series

- *Assembling Manifold Blocks for Concentrated Branching*
- *Same Flow Rate with Steel Piping. Half Size Body.*
- *Combination with 14 Types of Different Size Blocks*

Model Designation (Example)



① Type

● Inlet port

Code	Type	Code	Type	Code	Type	Code	Type
BA	Bush A	LB	Elbow	KR	Bulkhead Reducer	ST	Socket
BC	Bush C						

● Outlet port

Code	Type	Code	Type	Code	Type
HQ	Push-in Banjo	HB	Double Push-in Banjo	HT	Taper Banjo

● Extension port for outlet

Code	Type
HS	Straight Banjo

● Plug

Code	Type	Code	Type
PG	Plug	CP	Cap

● Different thread size and adaptor

Code	Type	Code	Type
BB	Bush B	BN	Male Screw Adaptor

② Joint connecting thread size

Code	08	12	14	18
Size (mm)	M8 × 1	M12 × 1	M14 × 1	M18 × 1

③ Air port size

● Fitting type

Code	04	06	08	10	12	16
Size (mm)	ø4	ø6	ø8	ø10	ø12	ø16

● Thread type

Thread size	Metric thread (mm)		Taper pipe thread			
Code	M5	M6	01	02	03	04
Size (mm)	M5 × 0.8	M6 × 1	R1/8	R1/4	R3/8	R1/2

● Joint connecting thread size type

Code	08	12	14	18
Size (mm)	M8 × 1	M12 × 1	M14 × 1	M18 × 1

④ Resin color

Code	No code	W
Color	Standard (Black)	Light-gray

Model Designation of Coupling Module (Example)

- Coupling module of outlet port

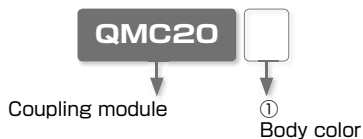

① Body color

Code	No code	W
Color	Standard (Black)	Light-gray

- ※ Joint connecting thread size of coupling module is M18x1 only
- ※ Use Light Coupling 20 series for the coupling module plug. See page 342.

Specifications

Fluid medium	Air
Max. operating pressure	1.0MPa
Max. vacuum	-100kPa
Operating temp. range	0~60℃ (No freezing)

Construction (MHQ)

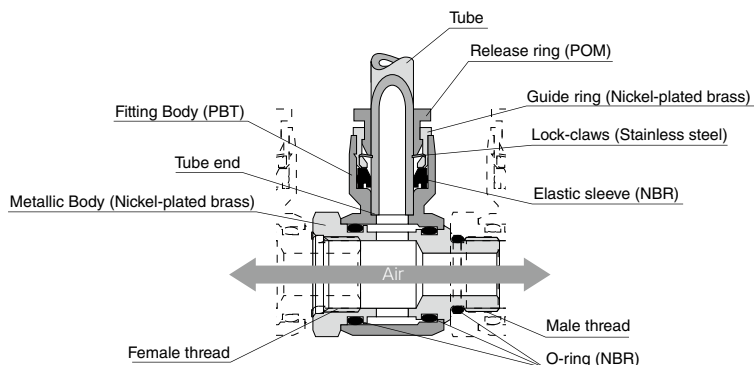



Main Block

FITTING

Detailed Safety Instructions

Before using PISCO products, be sure to read "Safety Instructions" and "Safety Instruction Manual" on page 23 to 27 and "Common Safety Instructions for Fittings" on page 33 to 35.

Warning

1. When many blocks are connected or bending load is applied on them, use Bracket. Connected equipment side or main block can be damaged without Bracket.

Caution

1. Use the main block spanners when assembling or disassembling. It may cause a difficulty to assemble or deformation of Main Block without using these spanners.
2. Refer to the following tightening torque for assembly.

Connecting thread size	Recommended tightening torque
M8×1	3.0 ~ 5.0N·m
M12×1	5.0 ~ 10.0N·m
M14×1	10.0 ~ 20.0N·m
M18×1	10.0 ~ 20.0N·m

Standard Size List

Inlet port

Type	Page	Connecting thread size	Thread size					
			R1/8	R1/4	R3/8	R1/2		
MBA Bush A	P.318	M8 × 1	●					
		M12 × 1	●	●	●			
		M14 × 1		●	●	●		
		M18 × 1			●	●		
MLE Elbow	P.318	M8 × 1	●					
		M12 × 1	●	●				
		M14 × 1		●	●	●		
		M18 × 1			●	●		
Type	Page	Connecting thread size	Tube O.D. (mm)					
MKR Bulkhead Reducer	P.319	M8 × 1	●	4	6	8	10	12
		M12 × 1			●		●	
		M14 × 1				●	●	●
		M18 × 1					●	●

Type	Page	Connecting thread size	Thread size				
			Rc1/8	Rc1/4	Rc3/8	Rc1/2	
MST Socket	P.319	M8 × 1	●				
		M12 × 1		●			
		M14 × 1			●		
		M18 × 1				●	
Type	Page	Connecting thread size	Thread size				
MBC Bush C	P.319	M8 × 1	●	M5 × 0.8	M6 × 1	R1/8	R1/4
		M12 × 1			●		
		M14 × 1				●	
		M18 × 1					●

Outlet port

Type	Page	Connecting thread size	Tube O.D. (mm)					
			4	6	8	10	12	16
MHC Push-in Banjo	P.320	M8 × 1	●	●				
		M12 × 1		●	●			
		M14 × 1			●	●	●	
		M18 × 1				●	●	●
Type	Page	Connecting thread size	Tube O.D. (mm)					
MHE Double Push-in Banjo	P.320	M14 × 1	●	10		12		
		M18 × 1				●		

Type	Page	Connecting thread size	Thread size				
			M5 × 0.8	M6 × 1	Rc1/8	Rc1/4	Rc3/8
MHT Taper Banjo	P.321	M8 × 1	●				
		M12 × 1		●	●		
		M14 × 1			●	●	●
		M18 × 1				●	●

Type	Page	Connecting thread size	Applicable Plug
MHC Module Socket	P.321	M18 × 1	Light Coupling 20 series

Extension port for outlet

Type	Page	Connecting thread size	Connecting thread size			
			M8 × 1	M12 × 1	M14 × 1	M18 × 1
MHS Straight Banjo	P.322	M12 × 1	●	●		
		M14 × 1		●	●	
		M18 × 1			●	●

Plug

Type	Page	Connecting thread size			
		M8 × 1	M12 × 1	M14 × 1	M18 × 1
MPC Plug	P.322	●	●	●	●
MCP Cap	P.322	●	●	●	●

Different thread size and adaptor

Type	Page	Connecting thread size	Connecting thread size		
			M8 × 1	M12 × 1	M14 × 1
MBB Bush B	P.323	M12 × 1	●		
		M14 × 1		●	
		M18 × 1			●

Type	Page	Connecting thread size	Thread size			
			M8 × 1	M12 × 1	M14 × 1	M18 × 1
MEN Male Screw Adaptor	P.323	M8 × 1	●			
		M12 × 1		●		
		M14 × 1			●	
		M18 × 1				●

Applicable Tube and Related Products

Polyurethane Tube.....P.596

Nylon Tube.....P.608

Light Coupling.....P.342

How to assemble

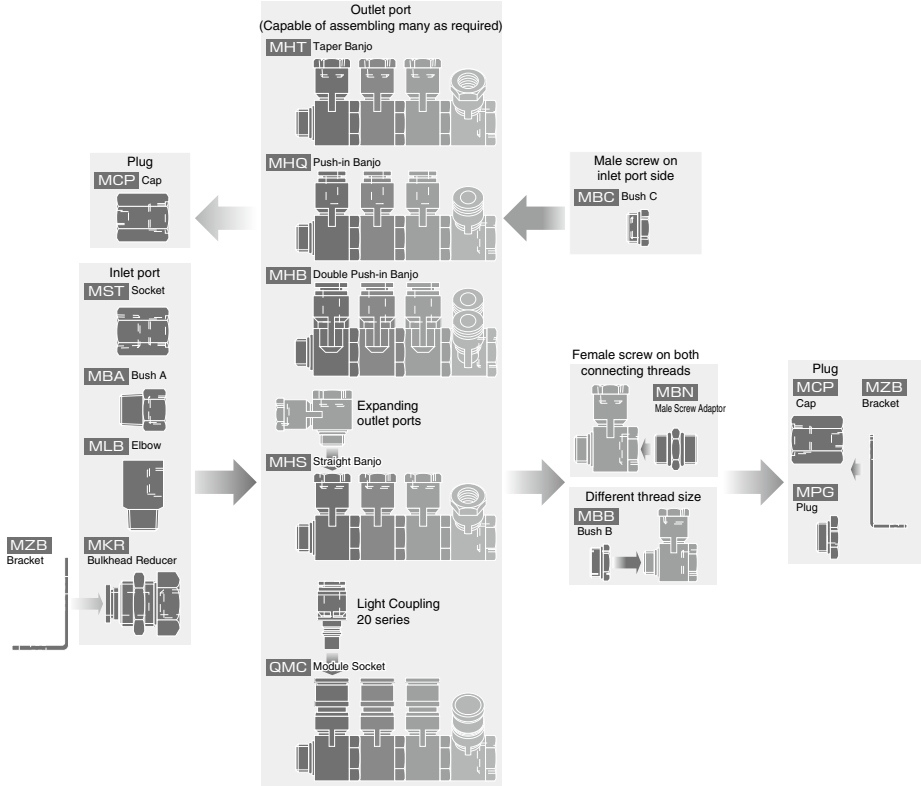

Main blocks can be connected, as long as each metric thread size is the same.

- Outlet port (4 types) Push-in Banjo (MHQ), Double Push-in Banjo (MHB), Taper Banjo (MHT), Module Socket (QMC).
(Capable of assembling as many as required)
- Inlet port (5 types) Bush A (MBA), Elbow (MLB), Bush C (MBC), Socket (MST), Bulkhead Reducer (MKR)
- Plug (2 types) Plug (MPG), Cap (MCP)
- Different thread size Bush B (MBB)
- Female screw on both connecting threads Male Screw Adaptor (MBN)
- Fixing Bracket Bracket (MZB)

Piping example

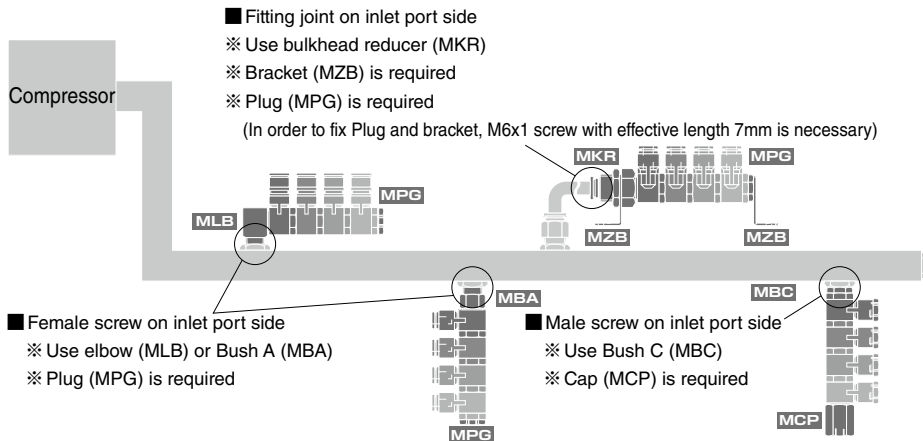

Assembly example

		Outlet port		
		Taper Banjo type	Push-in Banjo type	Double Push-in Banjo type
Inlet port	Bush A straight type			
	Elbow type			
	Bulkhead reducer type			

※ .When using Bulkhead Reducer on inlet port side and fix it, make sure to use Bracket (MZB).

How to insert and disconnect

1. How to insert and disconnect tubes

① Tube insertion

Insert a tube into Push-In Fitting up to the tube end. Lock-claws bite the tube and fix it automatically, then the elastic sleeve seals around the tube.

Refer to "2. Instructions for Tube Insertion" under "Common Safety Instructions for Fittings" .

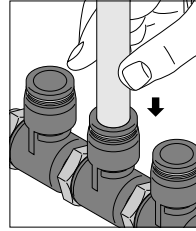

② Tube disconnection

The tube is disconnected by pushing release-ring to release Lock-claws.

Make sure to stop air supply before the tube disconnection.

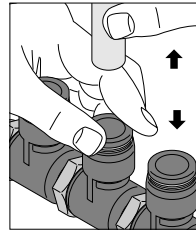

2. How to tighten thread

① Tightening thread

Use a spanner to tighten a hexagonal-column.

Refer to "Table 2: Recommended tightening torque / Sealock color / Gasket materials" under "4. Instructions for Installing a fitting" in "Common Safety Instructions for Fittings" .

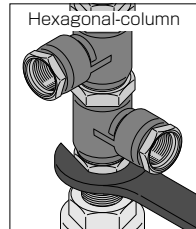

3. How to couple and uncouple coupling module

① Coupling

To couple, push the plug into the socket. No need to push down plug sleeve.

Refer to "Detailed Safety Instructions" of Light Coupling.

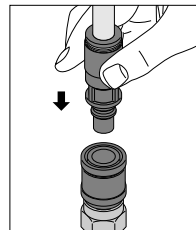

②. Uncoupling

To uncouple, push down the release sleeve to release Lock ball.

Refer to "Detailed Safety Instructions" of Light Coupling.

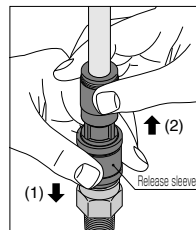

■ Inlet port

MBA Bush A

CAD

RoHS compliant

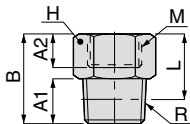

Unit : mm

Model code	R	M	A1	A2	B	L	H	Effective area (mm ²)	Weight (g)	CAD file name
MBA0801	R1/8	M8 × 1	8	8	20	16	12	24.5	11	TFMB-001
MBA1201	R1/8	M12 × 1	8	8.5	20	16	17	24.7	18	
MBA1202	R1/4		11		23	17		20		
MBA1203	R3/8		12		24	17.7		27		
MBA1402	R1/4	M14 × 1	11	8.5	23	17	19	42.7	23	
MBA1403	R3/8		12	8	24	17.7			25	
MBA1404	R1/2		13		25	16.8			22	
MBA1803	R3/8	M18 × 1	12	8.5	25	18.7	22	56.1	29	
MBA1804	R1/2		13			16.8			24	

※. "L" is a reference value for height dimension after tightening thread.

MLB Elbow

CAD

RoHS compliant

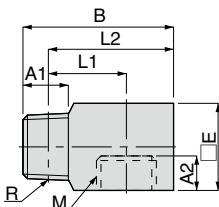

Unit : mm

Model code	R	M	A1	A2	B	L1	L2	□E	Effective area (mm ²)	Weight (g)	CAD file name
MLB0801	R1/8	M8 × 1	8	7	28	16	24	17	21.4	42	TFMB-002
MLB1201	R1/8	M12 × 1	8	8.5	29	15	25	19	24.5	48	
MLB1202	R1/4		11		32	16	26		40	50	
MLB1402	R1/4		11		37	19	31		42.7	80	
MLB1403	R3/8	M14 × 1	12	8.5	38	19.7	31.7	22	46	82	
MLB1404	R1/2		13		39	18.8	30.8			93	
MLB1803	R3/8	M18 × 1	12	9	44	23.7	37.7	27	49	141	
MLB1804	R1/2		13		45	22.8	36.8			157	

※. "L1" and "L2" are reference values for height dimensions after tightening thread.

MKR Bulkhead Reducer

RoHS compliant

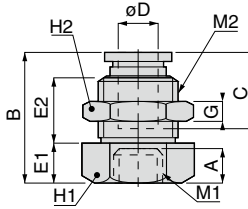

CAD

Unit : mm

Model code	Tube O.D. øD	M1	M2	A	B	E1	E2	Tube end C	G	H1	H2	Effective area (mm ²)	Weight (g)	CAD file name
MKR0804	4	M8 × 1	M12 × 1	8.5	26	8	13.4	14.9	4	14	14	5.6	19	TFMB-003
MKR0806	6		M14 × 1		28.1		14.9	17		17	17	11.5	29	
MKR1206	6	M12 × 1	M14 × 1	8.5	28.1	10	10.9	17	4	17	17	13.2	28	
MKR1208	8		M16 × 1		28.9		13.4	18.2		19	19	27.4	34	
MKR1210	10		M20 × 1		32.3		16.4	20.7	5	22	24	34.8	60	
MKR1408	8		M16 × 1		28.9	12	11.4	18.2	4	19	19	27.7	33	
MKR1410	10	M14 × 1	M20 × 1	8.5	32.3	10	16.4	20.7	5	24	24	41.7	64	
MKR1412	12		M22 × 1		34.9	12	17.4	23.3	6		27	54.7	78	
MKR1812	12	M18 × 1	M22 × 1	8.5	34.9	12	17.4	23.3	6	27	27	66.7	83	

※ . □ in Model code / Replaced with "W" for Light-gray color.

MST Socket

RoHS compliant

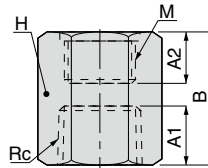

CAD

Unit : mm

Model code	Rc	M	A1	A2	B	H	Weight (g)	CAD file name
MST0801	Rc1/8	M8 × 1	8	9	20	12	12	TFMB-004
MST1202	Rc1/4	M12 × 1	11	9	24	17	29	
MST1403	Rc3/8	M14 × 1	12	10	27	22	57	
MST1804	Rc1/2	M18 × 1	15	10	28	27	84	

MBC Bush C

RoHS compliant

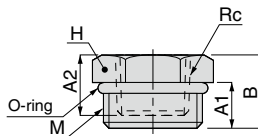

CAD

Unit : mm

Model code	Rc	M	A1	A2	B	H	Weight (g)	CAD file name
MBC08M5	M5 × 0.8	M8 × 1	7	5	11	10	3.8	TFMB-009
MBC12M6	M6 × 1	M12 × 1	7.5	6	11.5	14	9.6	
MBC1401	Rc1/8	M14 × 1	8	8	12	17	12	
MBC1802	Rc1/4	M18 × 1	8	11	13	19	17	

■ Outlet port

MHQ Push-in Banjo

CAD

RoHS compliant

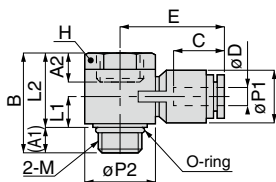

Unit : mm

Model code	Tube O.D. øD	M	A1	A2	B	L1	L2	øP1	øP2	Tube end C	E	H	Effective area (mm ²)	Weight (g)	CAD file name
MHQ0804 □	4	M8×1	6.5	7.5	25.7	8.2	19.2	10	15.4	14.9	22.2	14	4.7	16	TFMB-005
MHQ0806 □	6							12.5		17	24.2		7	17	
MHQ1206 □	6	M12×1	7	7.5	27.2	8.7	20.2	12.5	19.6	17	26.8	17	8.7	23	
MHQ1208 □	8							14.5		18.1	28.2		11	25	
MHQ1408 □	8	M14×1	8	8.5	31.2	10.2	23.2	14.5	24.4	18.1	30.2	22	16.7	39	
MHQ1410 □	10							18		20.2	32.5		19.5	42	
MHQ1412 □	12					11.7	21	23.4		35.2	21.1		45		
MHQ1812 □	12	M18×1	8	8.5	35.2	11.7	27.2	21	30	23.4	38.2	24	40.4	61	
MHQ1816 □	16			8	41.1	14.6	33.1	25	28	23.6	36.6	27	50.4	71	

※ □ in Model code / Replaced with "W" for Light-gray color.

MHB Double Push-in Banjo

CAD

RoHS compliant

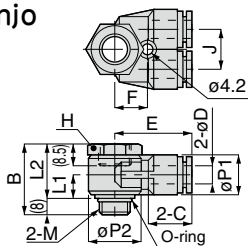

Unit : mm

Model code	Tube O.D. øD	M	B	L1	L2	øP1	øP2	Tube end C	E	J	F	H	Effective area (mm ²)	Weight (g)	CAD file name
MHB1410 □	10	M14×1	31.2	10.2	23.2	17.6	23	20.7	33.5	17	15	22	17.8	49	TFMB-007
MHB1812 □	12	M18×1	35.2	11.7	27.2	21	27	23.4	37.4	20	17	24	35.6	70	

※ □ in Model code / Replaced with "W" for Light-gray color.

Main Block

Outlet port

FITTING

MHT Taper Banjo

RoHS compliant

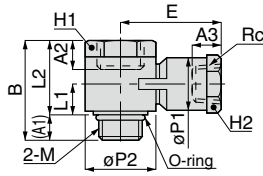

CAD

Unit : mm

Model code	Rc	M	A1	A2	A3	B	L1	L2	øP1	øP2	E	H1	H2	Effective area (mm ²)	Weight (g)	CAD file name	
MHT08M5	M5×0.8	M8 × 1	6.5	7.5	6	25.7	8.2	19.2	12.5	15.4	23.4	14	12	7.3	22	TFMB-006	
MHT08M6	M6 × 1				8				14.5				25.5	14	7.8		23
MHT0801	Rc1/8																
MHT12M6	M6 × 1	M12 × 1	7	7.5	6	27.2	8.7	20.2	12.5	19.6	26	17	12	9.7	28		
MHT1201	Rc1/8				8				14.5				27.5	14	12.4		29
MHT1401	Rc1/8	M14 × 1	8	8.5	8	31.2	10.2	23.2	14.5	24.4	29.5	22	14	16.1	44		
MHT1402	Rc1/4				11				21				34	19	21.4		59
MHT1802	Rc1/4	M18 × 1	8	8.5	11	35.2	11.7	27.2	21	30	37	24	19	36.9	75		
MHT1803	Rc3/8				8				12				41.1	14.6	33.1		25

※: □ in Model code / Replaced with "W" for Light-gray color.

321

QMC Module Socket

RoHS compliant

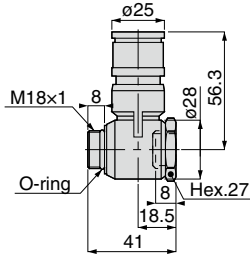

CAD

Model code	Weight (g)	CAD file name
QMC20	84	TFMC-004

※: □ in Model code / Replaced with "W" for Light-gray color.

※. Select the plug for the Coupling Module from Light Coupling 20 series. See page 342.

Expanding outlet port

MHS Straight Banjo

RoHS compliant

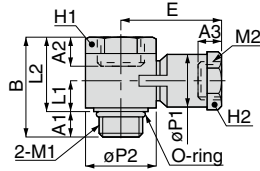

CAD

Unit : mm

Model code	M1	M2	A1	A2	A3	B	L1	L2	oP1	oP2	E	H1	H2	Effective area (mm ²)	Weight (g)	CAD file name
MHS1208	M12 × 1	M8 × 1	7	7.5	7	27.2	8.7	20.2	12.5	19.6	26	17	12	8.4	26	TFMB-007
MHS1212		M12 × 1			7.5		10.2						18	29.5	17	
MHS1412	M14 × 1	M12 × 1	8	8.5	7.5	31.2	10.2	23.2	18	24.4	31.5	22	17	20.8	49	
MHS1414		M14 × 1					8.5						11.7	21	34	
MHS1814	M18 × 1	M14 × 1	8	8.5	8.5	35.2	11.7	27.2	21	30	37	24	19	40.1	71	
MHS1818		M18 × 1					8						8.5	25	28	

* □ in Model code / Replaced with "W" for Light-gray color.

Plug

MPG Plug

RoHS compliant

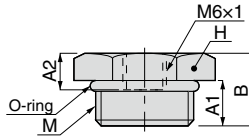

CAD

Unit : mm

Model code	M	A1	A2	B	H	Weight (g)	CAD file name
MPG08	M8 × 1	6	5	14	12	9	TFMB-008
MPG12	M12 × 1	6	5	9	14	7.9	
MPG14	M14 × 1	6	5	10	17	14	
MPG18	M18 × 1	7	6	12	19	25	

MCP Cap

RoHS compliant

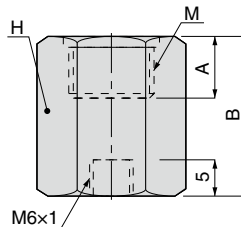

CAD

Unit : mm

Model code	M	A	B	H	Weight (g)	CAD file name
MCP08	M8 × 1	6.5	20	12	17	TFMB-008
MCP12	M12 × 1	7	22	14	22	
MCP14	M14 × 1	8	23	17	34	
MCP18	M18 × 1	8	25	22	64	

Adapter

MBB Bush B

RoHS compliant

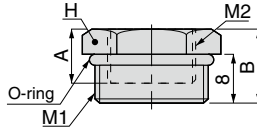

CAD

Unit : mm

Model code	M1	M2	A	B	H	Weight (g)	CAD file name
MBB1208	M12 × 1	M8 × 1	8	12	14	7.4	TFMB-009
MBB1412	M14 × 1	M12 × 1	7.5	20	17	21	
MBB1814	M18 × 1	M14 × 1	12	12	19	11	

MBN Male Screw Adaptor

RoHS compliant

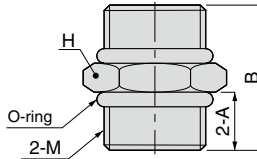

CAD

Unit : mm

Model code	M	A	B	H	Weight (g)	CAD file name
MBN0808	M8 × 1	7	18	10	5.6	TFMB-009
MBN1212	M12 × 1	8	20	14	13	
MBN1414	M14 × 1	8	20	17	16	
MBN1818	M18 × 1	8	20	19	19	

323

Standard Series

Mini Series

Stainless Series

Chemical Series

PP Series

EG Series

Anti-seal & Brass Series

De-temperature Control

Minimal Series

Stop Fitting Series

Pottery Series

Twist-Proof Fitting

Block and Connector

Bracket

MZB Bracket

RoHS compliant

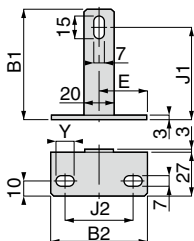

CAD

Unit : mm

Model code	B1	B2	J1	E	J2	Y	Weight (g)	Attachable Model	CAD file name
MZB061B	75	65	62.5	32.5	46	12	73	MPG, MCP	TFMB-011
MZB062B		80		40	63	13	84		
MZB161B	55	65	42.5	32.5	46	12	64	MPG, MCP	
MZB162B		80		40	63	13	73		

MZB Bracket

RoHS compliant

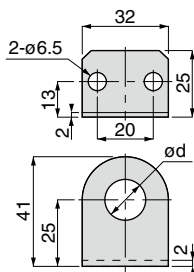

CAD

Unit : mm

Model code	ød	Weight (g)	Attachable Model	CAD file name
MZB06	7	28	MPG, MCP	TFMB-010
MZB12	13	26	MKR0804	
MZB14	15	26	MKR0806, MKR1206	
MZB16	17	25	MKR1208, MKR1408	
MZB20	21	23	MKR1210, MKR1410, MKR1810	
MZB22	23	22	MKR1412, MKR1812	

■ Assembly tool

SPANNER Spanners for main block

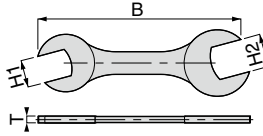

Unit : mm

Spanner	B	Hex. H1	Hex. H2	T	CAD file name
①	125	10	12	3.4	-
②	130	14	17	3.4	
③	140	19	22	4	
④	150	24	27	4	



SAFETY Instructions

This safety instructions aim to prevent personal injury and damage to properties by requiring proper use of PISCO products.

Be certain to follow ISO 4414 and JIS B 8370

ISO 4414 : Pneumatic fluid power...Recommendations for the application of equipment to transmission and control systems.

JIS B 8370 : General rules and safety requirements for systems and their components.

This safety instructions is classified into "Danger", "Warning" and "Caution" depending on the degree of danger or damages caused by improper use of PISCO products.



Danger

Hazardous conditions. It can cause death or serious personal injury.



Warning

Hazardous conditions depending on usages. Improper use of PISCO products can cause death or serious personal injury.



Caution

Hazardous conditions depending on usages. Improper use of PISCO products can cause personal injury or damages to properties.



Warning

1. Selection of pneumatic products

- ① A user who is a pneumatic system designer or has sufficient experience and technical expertise should select PISCO products.
- ② Due to wide variety of operating conditions and applications for PISCO products, carry out the analysis and evaluation on PISCO products. The pneumatic system designer is solely responsible for assuring that the user's requirements are met and that the application presents no health or safety hazards. All designers are required to fully understand the specifications of PISCO products and constitute all systems based on the latest catalog or information, considering any malfunctions.

2. Handle the pneumatic equipment with enough knowledge and experience

- ① Improper use of compressed air is dangerous. Assembly, operation and maintenance of machines using pneumatic equipment should be conducted by a person with enough knowledge and experience.

3. Do not operate machine / equipment or remove pneumatic equipment until safety is confirmed.

- ① Make sure that preventive measures against falling work-pieces or sudden movements of machine are completed before inspection or maintenance of these machine.
- ② Make sure the above preventive measures are completed. A compressed air supply and the power supply to the machine must be off, and also the compressed air in the systems must be exhausted.
- ③ Restart the machines with care after ensuring to take all preventive measures against sudden movements.

Disclaimer

1. PISCO does not take any responsibility for any incidental or indirect loss, such as production line stop, interruption of business, loss of benefits, personal injury, etc., caused by any failure on use or application of PISCO products.
2. PISCO does not take any responsibility for any loss caused by natural disasters, fires not related to PISCO products, acts by third parties, and intentional or accidental damages of PISCO products due to incorrect usage.
3. PISCO does not take any responsibility for any loss caused by improper usage of PISCO products such as exceeding the specification limit or not following the usage the published instructions and catalog allow.
4. PISCO does not take any responsibility for any loss caused by remodeling of PISCO products, or by combinational use with non-PISCO products and other software systems.
5. The damages caused by the defect of Pisco products shall be covered but limited to the full amount of the PISCO products paid by the customer.



SAFETY INSTRUCTION MANUAL

PISCO products are designed and manufactured for use in general industrial machines. Be sure to read and follow the instructions below.

Danger

1. Do not use PISCO products for the following applications.
 - ① Equipment used for maintaining / handling human life and body.
 - ② Equipment used for moving / transporting human.
 - ③ Equipment specifically used for safety purposes.

Warning

1. Do not use PISCO products under the following conditions.
 - ① Beyond the specifications or conditions stated in the catalog, or the instructions.
 - ② Under the direct sunlight or outdoors.
 - ③ Excessive vibrations and impacts.
 - ④ Exposure / adhere to corrosive gas, inflammable gas, chemicals, seawater, water and vapor. *
 - * Some products can be used under the condition above(④), refer to the details of specification and condition of each product.
2. Do not disassemble or modify PISCO products, which affect the performance, function, and basic structure of the product.
3. Turn off the power supply, stop the air supply to PISCO products, and make sure there is no residual air pressure in the pipes before maintenance and inspection.
4. Do not touch the release-ring of push-in fitting when there is a working pressure. The lock may be released by the physical contact, and tube may fly out or slip out.
5. Frequent switchover of compressed air may generate heat, and there is a risk of causing burn injury.
6. Avoid any load on PISCO products, such as a tensile strength, twisting and bending. Otherwise, there is a risk of causing damage to the products.
7. As for applications where threads or tubes swing / rotate, use Rotary Joints, High Rotary Joints or Multi-Circuit Rotary Block only. The other PISCO products can be damaged in these applications.
8. Use only Die Temperature Control Fitting Series, Tube Fitting Stainless SUS316 Series, Tube Fitting Stainless SUS316 Compression Fitting Series or Tube Fitting Brass Series under the condition of over 60°C (140° F) water or thermal oil. Other PISCO products can be damaged by heat and hydrolysis under the condition above.
9. As for the condition required to dissipate static electricity or provide an antistatic performance, use EG series fitting and antistatic products only, and do not use other PISCO products. There is a risk that static electricity can cause system defects or failures.
10. Use only Fittings with a characteristic of spatter-proof such as Anti-spatter or Brass series in a place where flame and weld spatter is produced. There is a risk of causing fire by sparks.
11. Turn off the power supply to PISCO products, and make sure there is no residual air pressure in the pipes and equipment before maintenance. Follow the instructions below in order to ensure safety.
 - ① Make sure the safety of all systems related to PISCO products before maintenance.
 - ② Restart of operation after maintenance shall be proceeded with care after ensuring safety of the system by preventive measures against unexpected movements of machines and devices where pneumatic equipment is used.
 - ③ Keep enough space for maintenance when designing a circuit.
12. Take safety measures such as providing a protection cover if there is a risk of causing damages or fires on machine / facilities by a fluid leakage.

⚠ Caution

1. Remove dusts or drain before piping. They may get into the peripheral machine / facilities and cause malfunction.
2. When inserting an ultra-soft tube into push-in fitting, make sure to place an Insert Ring into the tube edge. There is a risk of causing the escape of tube and a fluid leakage without using an Insert Ring.
3. The product incorporating NBR as seal rubber material has a risk of malfunction caused by ozone crack. Ozone exists in high concentrations in static elimination air, clean-room, and near the high-voltage motors, etc. As a countermeasure, material change from NBR to HNBR or FKM is necessary. Consult with PISCO for more information.
4. Special option "Oil-free" products may cause a very small amount of a fluid leakage. When a fluid medium is liquid or the products are required to be used in harsh environments, contact us for further information.
5. In case of using non-PISCO brand tubes, make sure the tolerance of the outer tube diameter is within the limits of Table 1.

● Table 1. Tube O.D. Tolerance

mm size	Nylon tube	Polyurethane tube	inch size	Nylon tube	Polyurethane tube
ø1.8mm	—	± 0.05mm	ø1/8	± 0.1mm	± 0.15mm
ø3mm	—	± 0.15mm	ø5/32	± 0.1mm	± 0.15mm
ø4mm	± 0.1mm	± 0.15mm	ø3/16	± 0.1mm	± 0.15mm
ø6mm	± 0.1mm	± 0.15mm	ø1/4	± 0.1mm	± 0.15mm
ø8mm	± 0.1mm	± 0.15mm	ø5/16	± 0.1mm	± 0.15mm
ø10mm	± 0.1mm	± 0.15mm	ø3/8	± 0.1mm	± 0.15mm
ø12mm	± 0.1mm	± 0.15mm	ø1/2	± 0.1mm	± 0.15mm
ø16mm	± 0.1mm	± 0.15mm	ø5/8	± 0.1mm	± 0.15mm

6. Instructions for Tube Insertion

- ① Make sure that the cut end surface of the tube is at right angle without a scratch on the surface and deformations.
- ② When inserting a tube, the tube needs to be inserted fully into the push-in fitting until the tubing edge touches the tube end of the fitting as shown in the figure below. Otherwise, there is a risk of leakage.

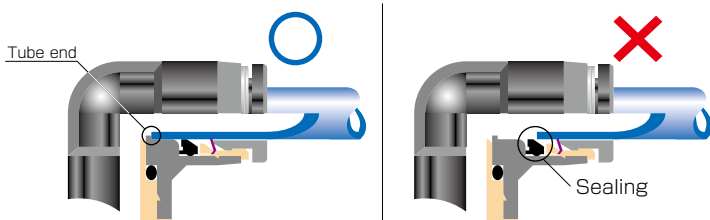

Tube is not fully inserted up to tube end.

- ③ After inserting the tube, make sure it is inserted properly and not to be disconnected by pulling it moderately.
- ※ When inserting tubes, Lock-claws may be hardly visible in the hole, observed from the front face of the release-ring. But it does not mean the tube will surely escape. Major causes of the tube escape are the followings;
- ① Shear drop of the lock-claws edge
 - ② The problem of tube diameter (usually small)
- Therefore, follow the above instructions from ① to ③, even lock-claws is hardly visible.

7. Instructions for Tube Disconnection

- ① Make sure there is no air pressure inside of the tube, before disconnecting it.
- ② Push the release-ring of the push-in fitting evenly and deeply enough to pull out the tube toward oneself. By insufficient pushing of the release-ring, the tube may not be pulled out or damaged by scratch, and tube shavings may remain inside of the fitting, which may cause the leakage later.

8. Instructions for Installing a fitting

- ① When installing a fitting, use proper tools to tighten a hexagonal-column or an inner hexagonal socket. When inserting a hex key into the inner hexagonal socket of the fitting, be careful so that the tool does not touch lock-claws. The deformation of lock-claws may result in a poor performance of systems or an escape of the tube.
- ② Refer to Table 2 which shows the recommended tightening torque. Do not exceed these limits to tighten a thread. Excessive tightening may break the thread part or deform the gasket and cause a fluid leakage. Tightening thread with tightening torque lower than these limits may cause a loosened thread or a fluid leakage.
- ③ Adjust the tube direction while tightening thread within these limits, since some PISCO products are not rotatable after the installation.

● Table 2: Recommended tightening torque / Sealock color / Gasket materials

Thread type	Thread size	Tightening torque	Sealock color	Gasket materials
Metric thread	M3 × 0.5	0.7N·m	—	SUS304 NBR
	M5 × 0.8	1.0 ~ 1.5N·m		
	M6 × 1	2 ~ 2.7N·m		
	M3 × 0.5	0.7N·m		POM
	M5 × 0.8	1 ~ 1.5N·m		
	M6 × 0.75	0.8 ~ 1N·m		
Taper pipe thread	M8 × 0.75	1 ~ 2N·m	White	—
	R1/8	4.5 ~ 6.5N·m		
	R1/4	7 ~ 9N·m		
	R3/8	12.5 ~ 14.5N·m		
Unified thread	R1/2	20 ~ 22N·m	—	SUS304, NBR
	No.10-32UNF	1.0 ~ 1.5N·m		
National pipe thread taper	1/16-27NPT	4.5 ~ 6.5N·m	White	—
	1/8-27NPT	4.5 ~ 6.5N·m		
	1/4-18NPT	7 ~ 9N·m		
	3/8-18NPT	12.5 ~ 14.5N·m		
	1/2-14NPT	20 ~ 22N·m		

※ These values may differ for some products. Refer to each specification as well.

9. Instructions for removing a fitting

- ① When removing a fitting, use proper tools to loosen a hexagonal-column or an inner hex bolt.
- ② Remove the sealant stuck on the mating equipment. The remained sealant may get into the peripheral equipment and cause malfunctions.

10. Arrange piping avoiding any load on fittings and tubes such as twist, tensile, moment load, shaking and physical impact. These may cause damages to fittings, tube deformations, bursting and the escape of tubes.

Common Safety Instructions for Fittings

Before selecting or using PISCO products, read the following instructions. Read the detailed instructions for individual series as well as the instructions below.

Warning

1. Do not use fittings with fluid medium other than air or water. (Water can be used with some series.) Contact us for using other kind of fluid medium except air and water.
2. Do not use fittings except Anti-spatter, Brass and Brass Compression Fitting series in a place where the flame and weld spatter is produced. There is a risk of causing fire by sparks.
3. As for applications where threads or tubes swing / rotate, use Rotary Joints, High Rotary Joints or Multi-Circuit Rotary Block only. The other PISCO products can be damaged in these applications.
4. Use only Die Temperature Control Fitting Series, Tube Fitting Stainless SUS316 Series, Tube Fitting Stainless SUS316 Compression Fitting Series or Tube Fitting Brass Series under the condition of over 60°C (140° F) water or thermal oil. Other PISCO products can be damaged by heat and hydrolysis under the condition above.
5. As for the condition required to dissipate static electricity or provide an antistatic performance, use EG Series fitting and antistatic products only, and do not use other PISCO products. There is a risk that static electricity can cause system defects or failures.
6. Avoid any load on PISCO products, such as a tensile strength, twisting and bending. Otherwise, there is a risk of causing damage to the products.

⚠ Caution

1. In case of using non-PISCO brand tubes, make sure the tolerance of the outer tube diameter is within the following limits of Table 1.

● Table 1. Tube O.D. Tolerance

mm size	Nylon tube	Urethane tube	inch size	Nylon tube	Urethane tube
ø1.8mm	—	± 0.05mm	ø1/8	± 0.1mm	± 0.15mm
ø3mm	—	± 0.15mm	ø5/32	± 0.1mm	± 0.15mm
ø4mm	± 0.1mm	± 0.15mm	ø3/16	± 0.1mm	± 0.15mm
ø6mm	± 0.1mm	± 0.15mm	ø1/4	± 0.1mm	± 0.15mm
ø8mm	± 0.1mm	± 0.15mm	ø5/16	± 0.1mm	± 0.15mm
ø10mm	± 0.1mm	± 0.15mm	ø3/8	± 0.1mm	± 0.15mm
ø12mm	± 0.1mm	± 0.15mm	ø1/2	± 0.1mm	± 0.15mm
ø16mm	± 0.1mm	± 0.15mm	ø5/8	± 0.1mm	± 0.15mm

2. Instructions for Tube Insertion

- ① Make sure that the cut end surface of the tube is at right angle without a scratch on the tube surface and deformations.
- ② When inserting a tube, the tube needs to be inserted fully into the push-in fitting until the tubing edge touches the tube end of the fitting as shown in the figure below. Otherwise, there is a risk of leakage.

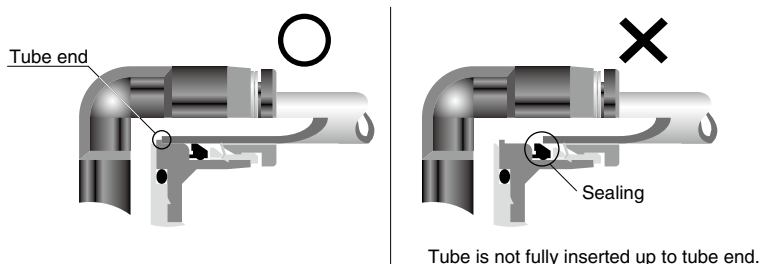

- ③ After inserting the tube, make sure it is inserted properly and not to be disconnected by pulling it moderately.

3. Instructions for Tube Disconnection

- ① Make sure there is no air pressure inside of the tube, before disconnecting it.
- ② Push the release-ring of the push-in fitting evenly and deeply enough to pull out the tube toward oneself. By insufficient pushing of the release-ring, the tube may not be pulled out or damaged by scratch, and tube shavings may remain inside of the fitting, which may cause the leakage later.

4. Instructions for Installing a fitting

- ① When installing a fitting, use proper tools to tighten a hexagonal-column or an inner hexagonal socket. When inserting a hex key into the inner hexagonal socket of the fitting, be careful so that the tool does not touch lock-claws. The deformation of lock-claws may result in a poor performance of systems or an escape of the tube.
- ② Refer to Table 2 which shows the recommended tightening torque. Do not exceed these limits to tighten a thread. Excessive tightening may break the thread part or deform the gasket and cause a fluid leakage. Tightening thread with tightening torque lower than these limits may cause a loosened thread or a fluid leakage.
- ③ Adjust the tube direction while tightening thread within these limits, since some PISCO products are not rotatable the installation.

● Table 2: Recommended tightening torque / Sealock color / Gasket materials

Thread type	Thread size	Tightening torque	Sealock color	Gasket materials
Metric thread	M3 × 0.5	0.7N·m	—	SUS304 NBR
	M5 × 0.8	1.0 ~ 1.5N·m		
	M6 × 1	2 ~ 2.7N·m		
	M3 × 0.5	0.5 ~ 0.6N·m		POM
	M5 × 0.8	1 ~ 1.5N·m		
	M6 × 0.75	0.8 ~ 1N·m		
	M8 × 0.75	1 ~ 2N·m		
Taper pipe thread	R1/8	7 ~ 9N·m	White	—
	R1/4	12 ~ 14N·m		
	R3/8	22 ~ 24N·m		
	R1/2	28 ~ 30N·m		
Unified thread	No.10-32UNF	1.0 ~ 1.5N·m	—	SUS304, NBR
National pipe thread taper	1/16-28NPT	7 ~ 9N·m	White	—
	1/8-27NPT	7 ~ 9N·m		
	1/4-18NPT	12 ~ 14N·m		
	3/8-18NPT	22 ~ 24N·m		
	1/2-14NPT	28 ~ 30N·m		

※. These values may differ for some products. Refer to each specification as well

5. Instructions for removing a fitting

- ① When removing a fitting, use proper tools to loosen a hexagonal-column or an inner hexagonal socket.
- ② Remove the sealant stuck on the mating equipment. The remained sealant may get into the peripheral equipment and cause malfunctions.

6. Arrange piping avoiding any load on fittings and tubes such as twist, tensile, moment load, shaking and physical impact. These may cause damages to fittings, tube deformations, bursting and the escape of tubes.