

MEHC2 series

ELECTRIC GRIPPER (WITH MOTOR)

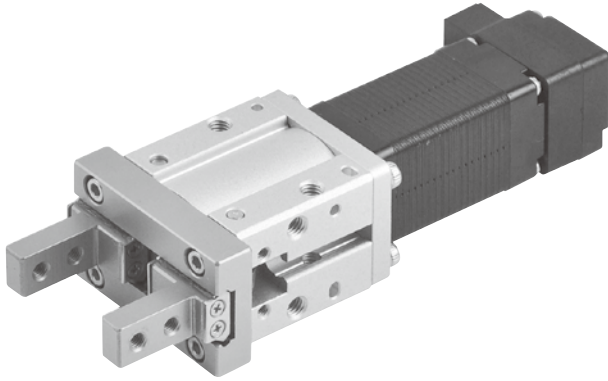

Specification

Model	MEHC2	
Size	16	25
Gripping force *1 (N)	19.5	26
Opening / Closing stroke *2 (mm)	6	14
Lead (mm)	1.5	
Stroke *2,3 (mm)	3.5	7.4
Positioning repeatability *4 (mm)	±0.02	
Motor size (mm)	□20	□28
Rated voltage	DC24 V ±10%	
Gripping mass *5 (kg)	0.4	0.8
Weight (g)	222	662

*1. Gripping force tolerance ± 20%.

*2. The opening/ closing stroke and the movement stroke of the nut are nonlinear.

*3. The operating stroke should be set within the range to avoid the screw getting locked.

*4. When under same procedure, the Positioning repeatability of workpiece.

*5. The gripping mass may change depending on the gripper attachments or friction coefficient.

Motor type	Step motor	Transmission	Lead screw
Environment	Standard	Guide type	Linear guideway

Order example

MEHC2 - 16 - N F - CK10 03 N 015

Model

Size

16

25

Spec. and type

Blank: Standard

N: Narrow

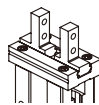
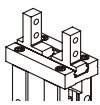

1: Standard (Side tapped)

N1: Narrow (Side tapped)

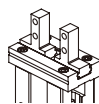
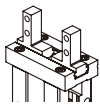

2: Standard (Through hole)

N2: Narrow (Through hole)

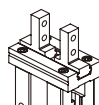
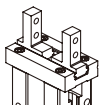

3: Flat

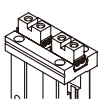

Motor cable entry

Blank: Parallel

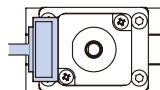

F: Perpendicular

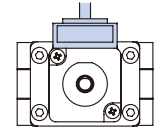

Controller

CK10

I/O type

N

NPN

I/O cable length

015

1.5 m

03

3 m

* Standard: 1.5 m

Power + Encoder cable of motor

015

1.5 m

03

3 m

05

5 m

* Standard: 3 m

Evaluation of gripping force

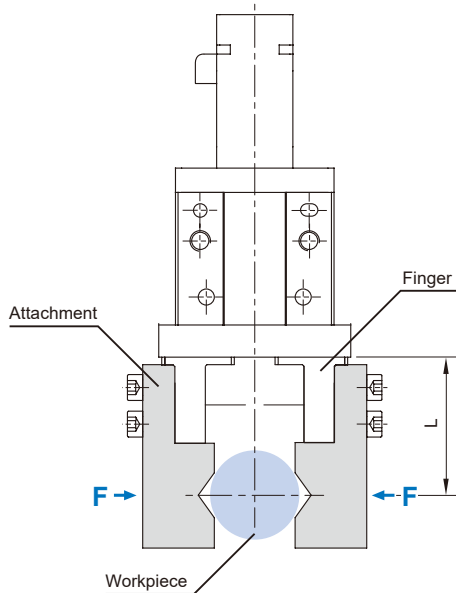

L = Gripping point distance
F = Gripping force

Allowable moment and force (N.m / N)

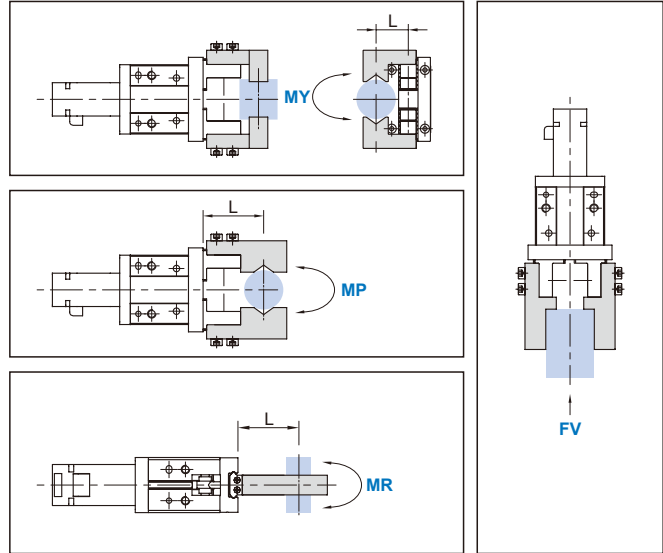

Model	MY	MP	MR	FV
	Max. moment (N.m)			Max. force (N)
MEHC2-16	0.68	0.68	1.36	98
MEHC2-25	1.94	1.94	3.88	255

Diagram

ø16 Gripping force accuracy: ±20%(F.S.)

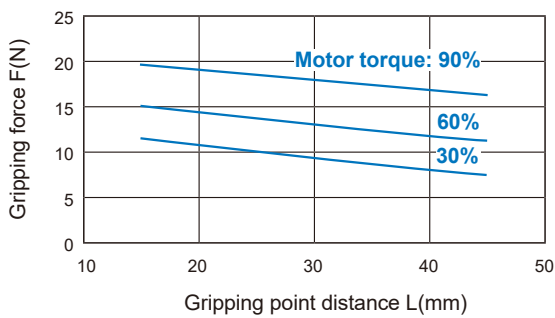

ø25 Gripping force accuracy: ±20%(F.S.)

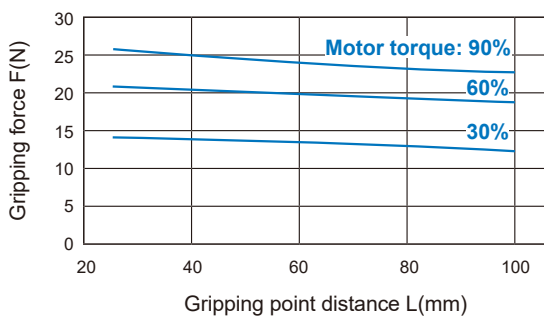

Model selection steps

1. Calculate the required gripping force according to the weight and the friction.
2. According to the required gripping force and the holding position : L, preselect suitable gripper models by comparing gripper performance charts.
3. According to the preselecting results, calculate the available load.

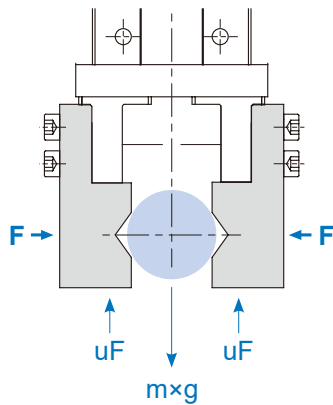

Gripping force calculation

the conditions for the workpiece not to drop is, $n \times uF > m \times g$

Therefore, $F \geq \frac{m \times g}{n \times u}$

If the safety factor is "a", then F is $F \geq \frac{m \times g}{n \times u} \times a$

F	Gripping force of single finger (N)
n	Number of finger
u	Coefficient of friction between the attachments and the workpiece
m	Workpiece mass (kg)
g	Gravitational acceleration (=9.8m/s ²)
a	Safety factor

*1. For normal gripping and carrying usage, the recommended safety factor "a" is 4.

*2. If the Coefficient of friction μ is unknown, calculate with $\mu = 0.1$

Available load calculation

$$\frac{MY_{real}}{MY} + \frac{MP_{real}}{MP} + \frac{MR_{real}}{MR} < 1$$

Model selection example

Condition:

The material of soft fingers and workpiece are aluminum. Coefficient of friction is 1.15. The workpiece weight is 1.2 kg. Holding position C is 30mm and A is 25 mm.

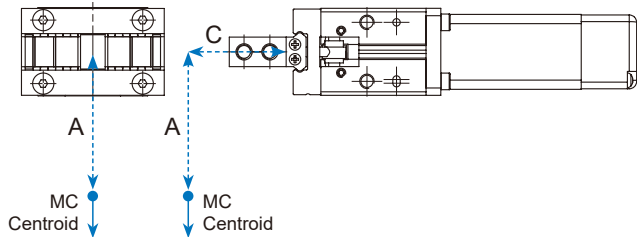

Step 1: Required gripping force calculation

$$F > \frac{mg}{nu} \times a \rightarrow F > \frac{1.2 \times 9.8}{2 \times 1.15} \times 4 = 20.45 \text{ N}$$

After calculation, the gripper must provide a gripping force greater than 20.45N.

Step 2: Compare the available gripping force

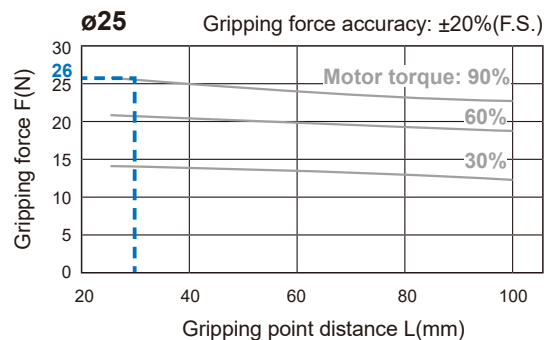
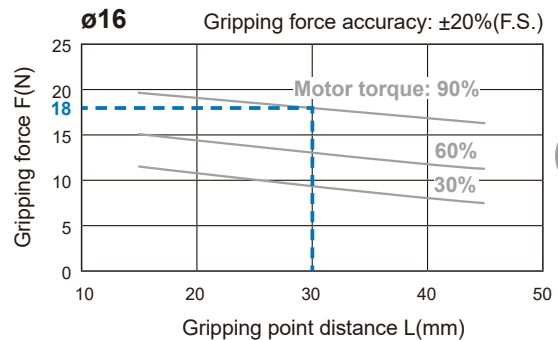

After comparison, the gripping force of MEHC2-25 meets the requirements.

Step 3: Calculate the available load

$$MR = 1.2 \times 9.8 \text{ N} \times 0.03 \text{ m} = 0.3528 \text{ N} \cdot \text{m}$$

MY = None

MP = None

$$\frac{MY_{real}}{MY} + \frac{MP_{real}}{MP} + \frac{MR_{real}}{MR} = \frac{0.3528}{3.88} < 1$$

After comparison, the loads are all within the available range, so MEHC2-25 grippers can be used.

MEHC2 Inside structure & Parts list

ELECTRIC GRIPPER (WITH MOTOR)



Mindman

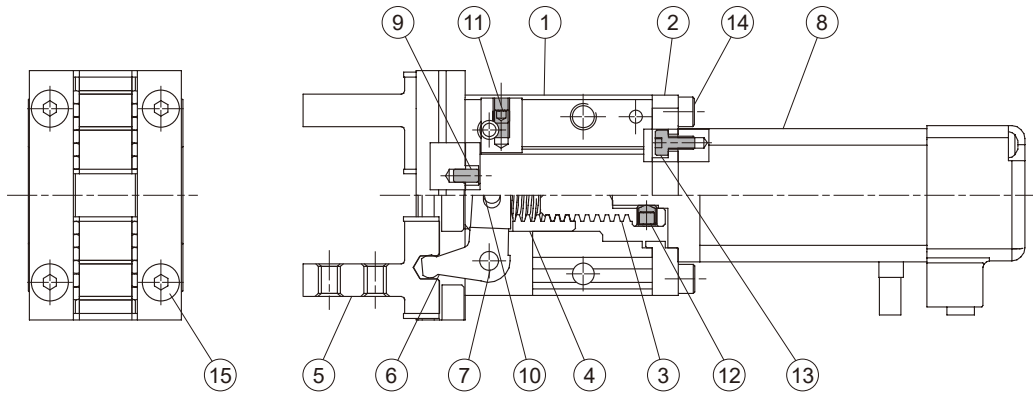

Material

No.	Part name	Material	Q'y
1	Body	Aluminum alloy	1
2	Motor fixed plate	Aluminum alloy	1
3	Screw	Stainless steel	1
4	Nut	Bronze	1
5	Gripping set	Stainless steel (*)	1
6	Rod	Stainless steel	2
7	Pin	Carbon steel	2
8	Step motor	-	1
9	Locating pin	Bearing steel	3
10	Pin	Steel	1
11	Screw	Stainless steel	4
12	Screw	Carbon steel	1
13	Bolt	Stainless steel	4
14	Bolt	Stainless steel	4
15	Bolt	Stainless steel	4

* Bearing steel balls as standard.

MEHC2 Dimensions 16

ELECTRIC GRIPPER (WITH MOTOR)

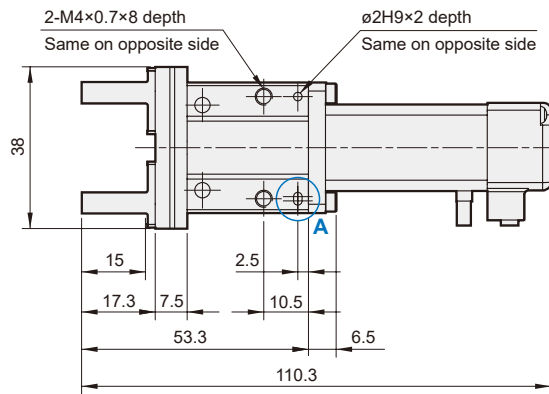
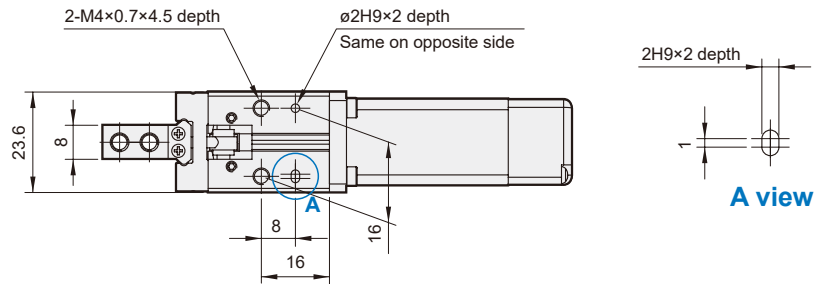

Standard

1: Standard (Side tapped)

2: Standard (Through hole)

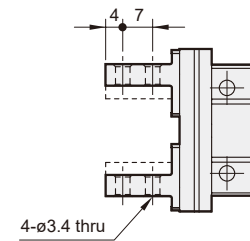
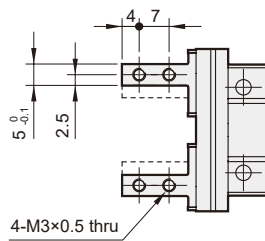
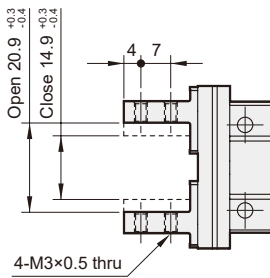

N: Narrow

N1: Narrow (Side tapped)

N2: Narrow (Through hole)

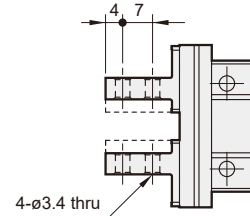
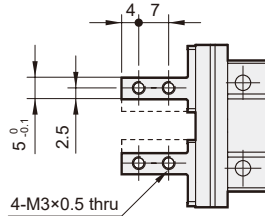
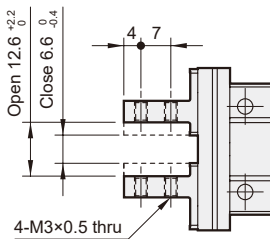

3: Flat

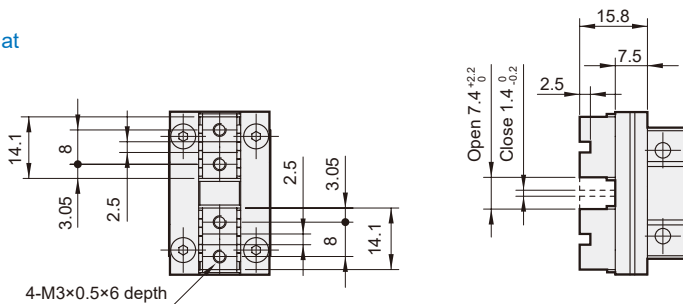

MEHC2 Dimensions 25

ELECTRIC GRIPPER (WITH MOTOR)

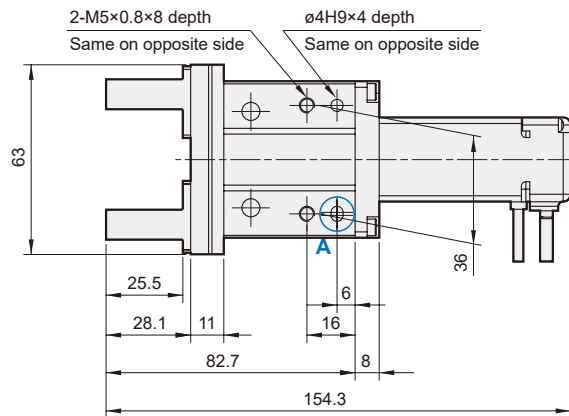
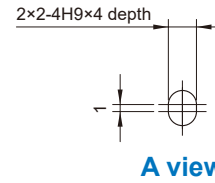
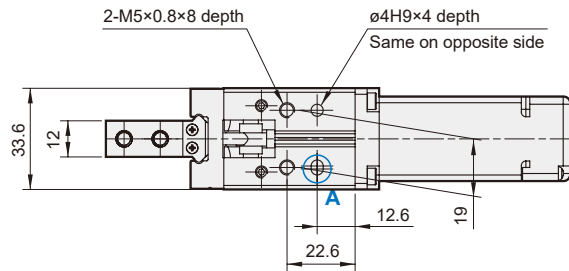

Standard

1: Standard (Side tapped)

2: Standard (Through hole)

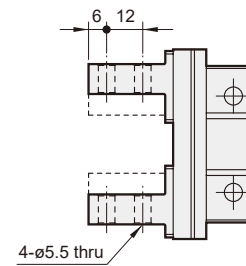
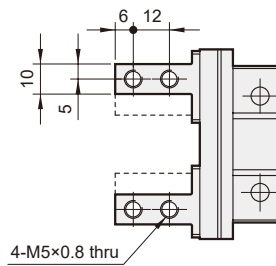
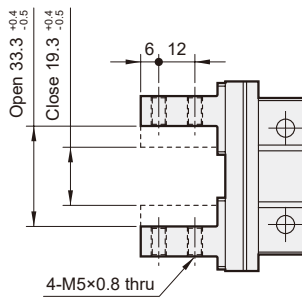

N: Narrow

N1: Narrow (Side tapped)

N2: Narrow type (Through hole)

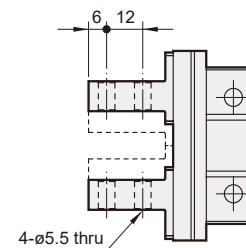
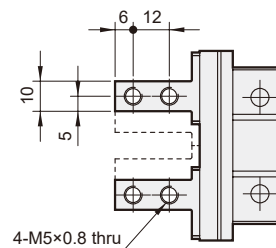
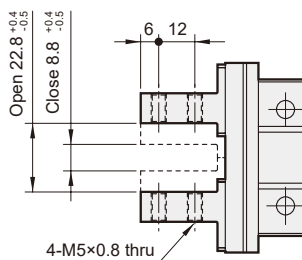

3: Flat

