

### Features

- Twin rack and pinion fitted as standard.
- Can be adjusted between 0 and 190 degrees.
- Simple mounting of sensors.
- Magnetic as standard.

### Specification

Model	MCRB				
Acting type	Double acting				
Tube I.D. (mm)	16	20	25	32	
Port size	Rc1/8				
Medium	Air				
Operating pressure range	0.1~1 MPa				
Proof pressure	1.5 MPa				
Ambient temperature	-5~+60°C (No freezing)				
Lubrication	Not required				
Cushion	NBR spacer				
Allowable kinetic energy	Cushion pad	0.007J	0.040J	0.081J	0.32J
	Cushion	0.039J	0.116J	0.294J	1.6J
Stable rotation time regulation range	0.2~1.0 s/90°				
Sensor switch (*)	RCD				
Weight (kg)	0.7	1.16	1.57	3.07	

### Order example

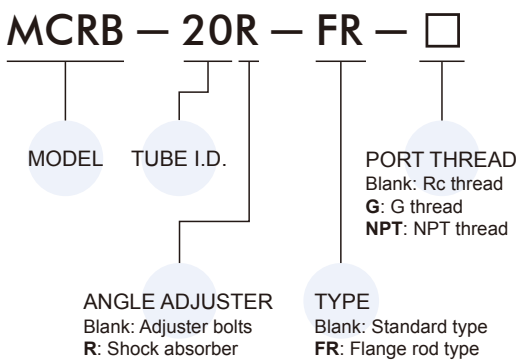

\* RCD specification, please refer to page 5-5.

### Symbol

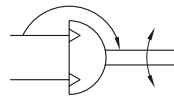

### Action profile

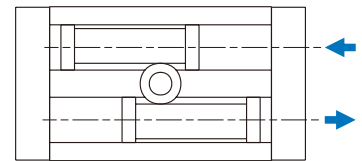

### Installation guide of shock absorber

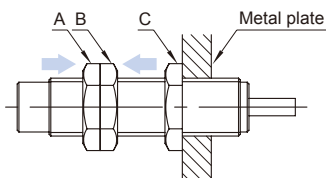

- 1 Install 3 nuts on the shock absorber as the picture shown.
- 2 Bind the A nut and B nut together via tightening them with different rotating direction.
- 3 Hold B nut and rotate C nut to bind the plate and C nut together.
- 4 Unbind the A nut and B nut. The installation is complete.

### Installation of sensor switch

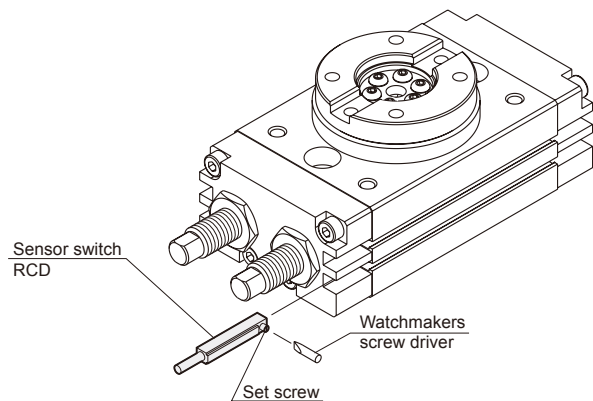

### Torque diagram

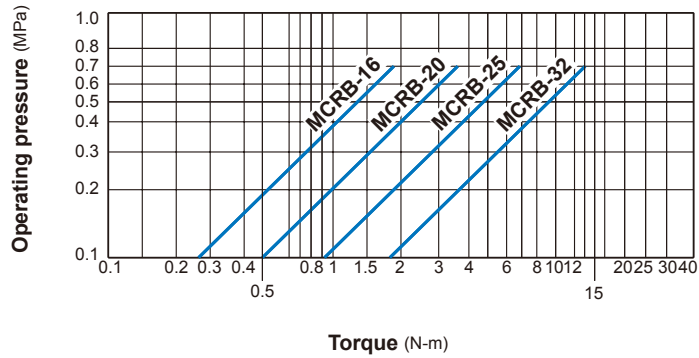

### Theoretic force

Unit: N-m

Type	MCRB				
Tube I.D.	16	20	25	32	
Operating pressure (MPa)	0.1	0.26	0.5	0.91	1.88
	0.2	0.52	1	1.81	3.78
	0.3	0.78	1.5	2.72	5.66
	0.4	1.04	2.01	3.62	7.56
	0.5	1.31	2.51	4.55	9.44
	0.6	1.57	3	5.45	11.32
	0.7	1.83	3.5	6.36	13.23

### Allowable load

Set the load and moment to be applied to the table within the allowable values shown in the table below. (Values outside of limitations will cause excessive play, deteriorate accuracy, and shorten service life.)

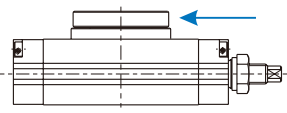
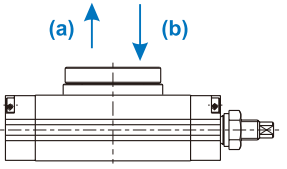
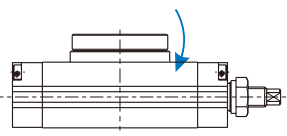
Pictures					
	Tube I.D.	Allowable radial load (N)	Allowable thrust load (N)		Allowable moment (N.m)
			(a)	(b)	
16	78	74	78	2.4	
20	196	197	363	5.3	
25	314	296	451	9.7	
32	390	493	708	18	

### Rotating direction and angle

- When the port 1 is pressurized, the flange rotates in clockwise (CW) direction.
- When the port 2 is pressurized, the flange rotates in counter-clockwise (CCW) direction.

The rotating angle range can be adjust by the method shown as right figure.

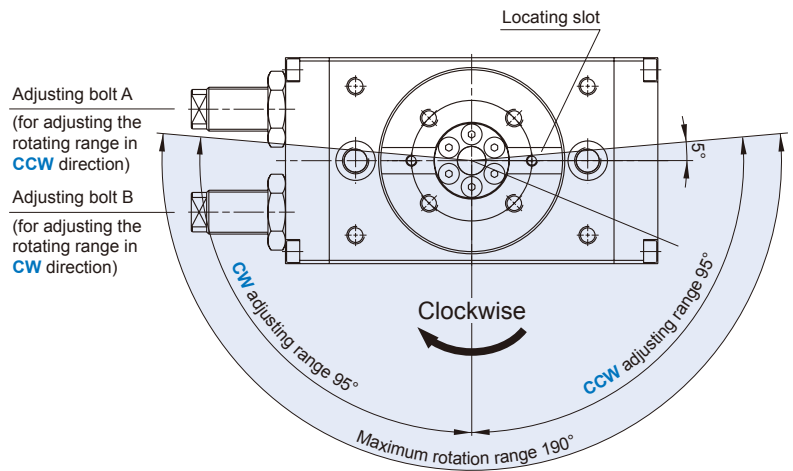
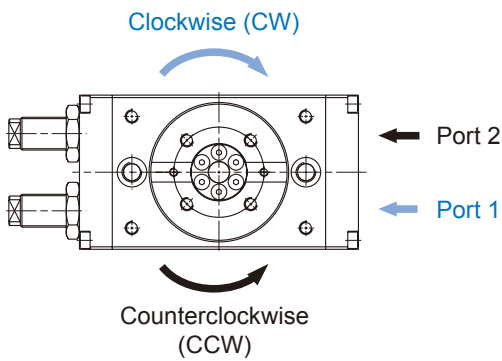

#### NOTE

- The figure shows the rotating range and use the pin hole as indicator.
- The locating slot in the figure locates at the situation which the CCW & CW rotating range are both adjusted at 90°.

### Rotating range adjusting example

- The followed figures show the rotating range of different adjustment via bolt A and B. (The drawings also show the rotation ranges of the locating slot.)

#### 190° (Max) Rotation

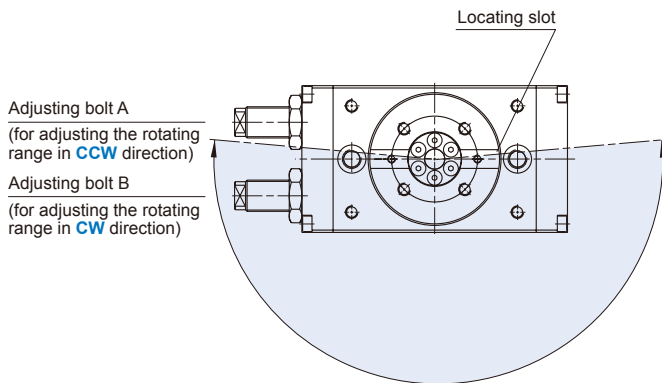

#### 180° Rotation

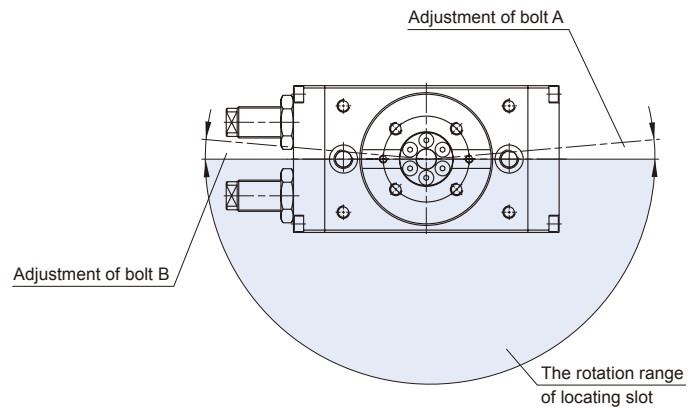

#### 90° Rotation

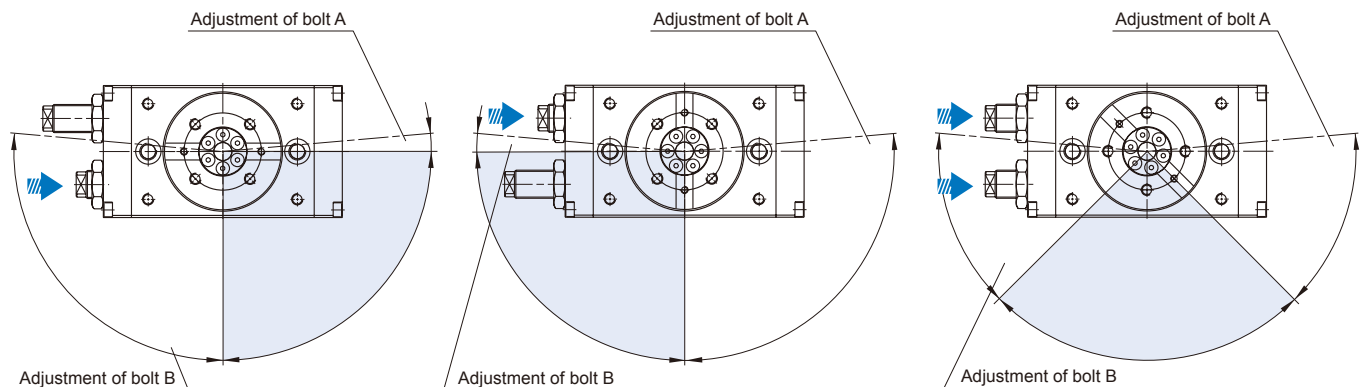

## ROTARY ACTUATOR

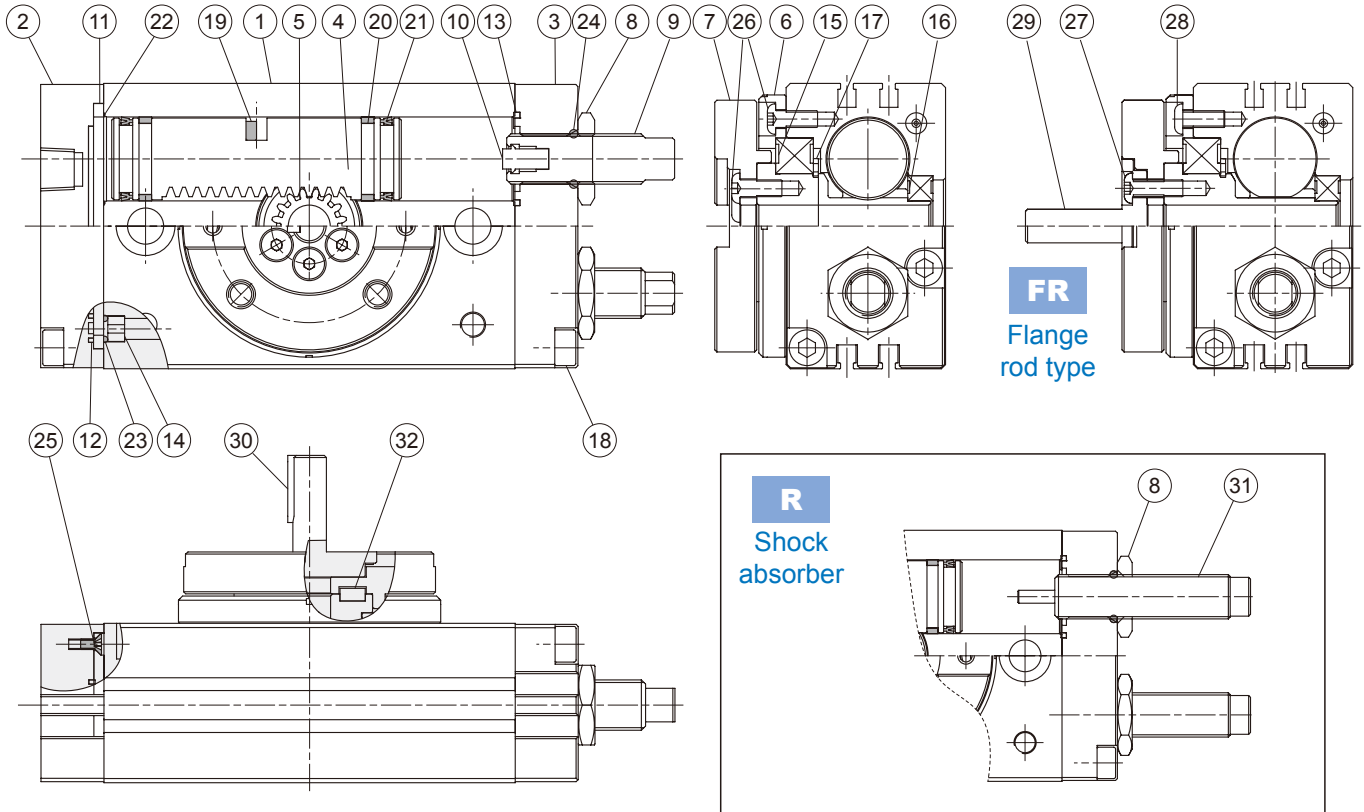

### Material

No.	Part name	Material	Q'y	Repair kits (inclusion)
1	Body	Aluminum alloy	1	
2	Cover	Aluminum alloy	1	
3	End cover	Aluminum alloy	1	
4	Piston	Stainless steel	2	
5	Pinion	SCM	1	
6	Bearing retainer	Aluminum alloy	1	
7	Table	Aluminum alloy	1	
8	Seal nut	Stainless steel	2	
9	Adjusting bolt	Stainless steel	2	
10	Cushion pad	NBR	2	●
11	Plate	Aluminum alloy	1	
12	Packing	NBR	1	●
13	Packing	NBR	2	●
14	Fixed	Copper	2	
15	Ball bearing	Bearing steel	1	
16	Ball bearing	Bearing steel	1	
17	Snap ring	Spring steel	1	
18	Bolt	Stainless steel	8	
19	Magnet	Magnet material	2	
20	Wear ring	Resin	4	

No.	Part name	Material	Q'y	Repair kits (inclusion)
21	Piston packing	NBR	4	●
22	O-ring	NBR	2	●
23	O-ring	NBR	2	●
24	O-ring	NBR	2	●
25	Screw	Carbon steel	2	
26	Bolt	Carbon steel	10	
27	Bolt *1	Carbon steel	6	
28	Bolt *1	Carbon steel	4	
29	Rotate shaft *1	Carbon steel	1	
30	Round key *1	Carbon steel	1	
31	Shock absorber *2	-	2	
32	Round key	Carbon steel	1	

### Order example of repair kits

Tube I.D.	Repair kits
ø16	<b>PS-MCRB-16</b>
ø20	<b>PS-MCRB-20</b>
ø25	<b>PS-MCRB-25</b>
ø32	<b>PS-MCRB-32</b>

\*1. No.27~30 for (FR) flange rod type.

\*2. Only suit for option (R) shock absorber.

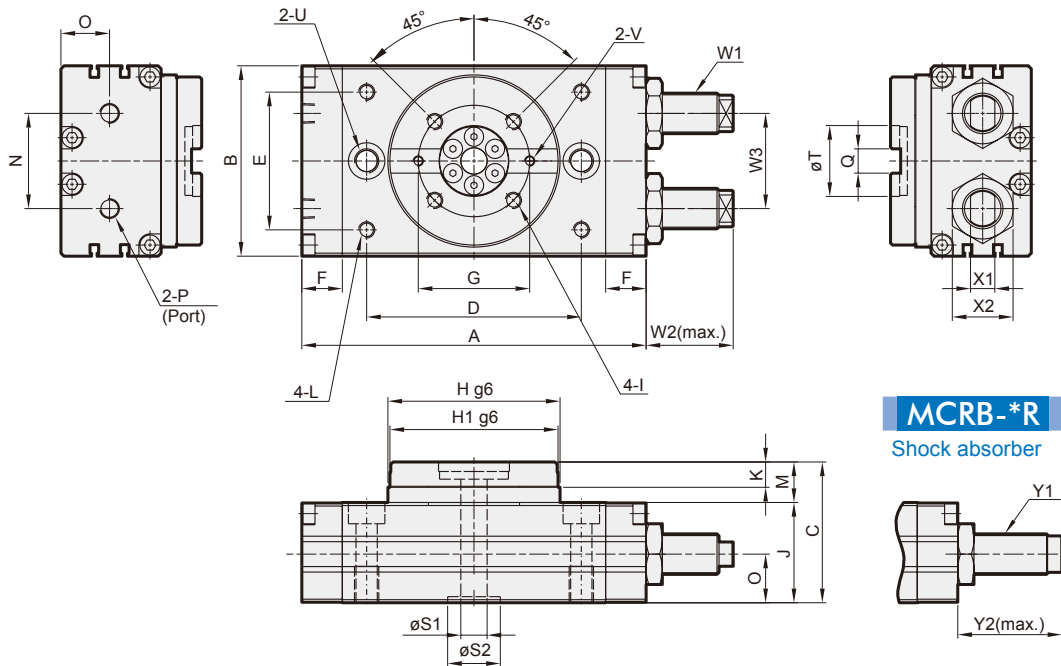

**MCRB-\*R**  
Shock absorber

Code Tubr I.D.	A	B	C	D	E	F	G	H	H1	I	J	K	L	M	N	O	P
16	108	58	47	62	38	15	38	50	48	M5×7dp,P.C.D38	33	8	M5×8dp	14	26	15.5	Rc1/8
20	128	68	55	78	47	15	46	62.5	60	M6×7dp,P.C.D46	38	10	M6×8dp	17	27	18.5	Rc1/8
25	135.5	77	58.5	84	55	15.5	48	67	65	M6×9dp,P.C.D48	41.5	10	M6×8dp	17	37	20	Rc1/8
32	170	94	69.5	106	68	20	55	85	83	M8×10dp,P.C.D55	49.5	12.5	M8×8.5dp	20	47	24	Rc1/8

Code Tubr I.D.	Q	S1	S2	T	U	V	W1	W2
16	8 <sup>+0.03</sup> <sub>-0</sub> (wide)×3.3dp	6	17 (H7)×2.5dp	24 (H7)×3dp	2- $\phi 6.8$ thru, $\phi 11 \times 6.5$ dp,M8×12dp(sink)	M3×4dp	M10×1.0	27
20	10 <sup>+0.03</sup> <sub>-0</sub> (wide)×3.5dp	10	22 (H7)×2.5dp	32 (H7)×3dp	2- $\phi 8.6$ thru, $\phi 14 \times 8.5$ dp,M10×15dp(sink)	M4×6dp	M12×1.0	23
25	12 <sup>+0.03</sup> <sub>-0</sub> (wide)×4dp	13	22 (H7)×3dp	32 (H7)×3.7dp	2- $\phi 8.6$ thru, $\phi 14 \times 8.5$ dp,M10×15dp(sink)	M4×5dp	M14×1.5	36
32	12 <sup>+0.03</sup> <sub>-0</sub> (wide)×5dp	13	26 (H7)×3dp	35 (H7)×4.7dp	2- $\phi 10.5$ thru, $\phi 18 \times 10.5$ dp,M12×18dp(sink)	M5×5dp	M20×1.5	43

Code Tubr I.D.	W3	X1	X2	Y1	Y2
16	26	7	17	FK-1008L-S	24
20	32	8	19	FK-1210L-S	36.5
25	37	8	22	FK-1412L-S	41
32	47	12	30	FK-2016L-S	55

### Flange rod type

$\phi 16$

$\phi 20 \sim \phi 32$

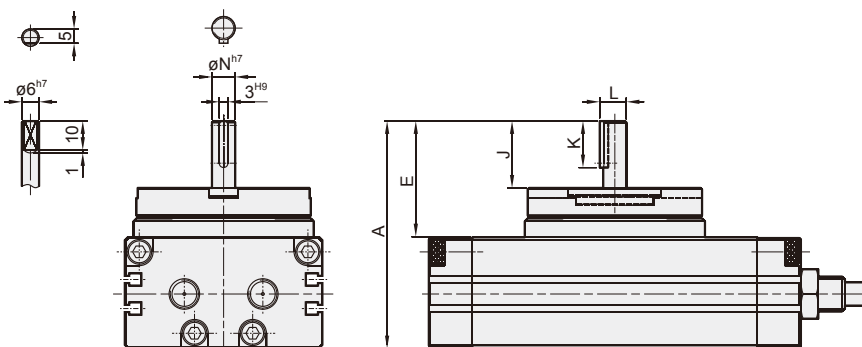

Code Tubr I.D.	A	E	J	K	L	N
16	64.5	31.5	17.5	-	-	-
20	78	40	23	16	9.2	8
25	81.5	40	23	20	11.2	10
32	109.5	60	40	20	13.2	12

\* Other dimensions are the same as standard type.