



### Features

- Copper lining structure embedded.
- Grease nipple as standard.
- Carbon steel body.
- High carbon chromium bearing steel.

### Order example

**PHS 25 – M24×1.5**

MODEL

THREAD SIZE

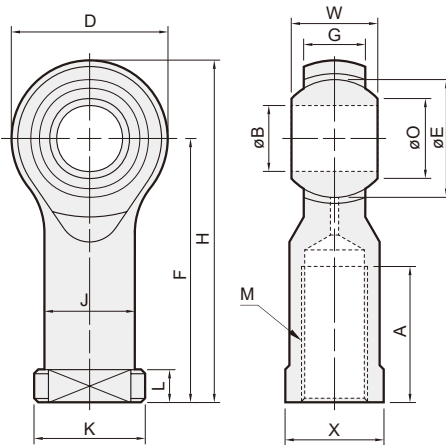

Model	Dimensions (mm)														Static fracture minimal radial load (kgf)	Dynamic eff. load (kgf)		Weight (g)
	A	B	D	E	F	G	H	J	K	L	M	O	W	X		Radial	Axial	
PHS 5-M5×0.8	14	5	16	11.11	27	7	35	9	12	4	M5×0.8	7.71	8	9	930	620	230	18
PHS 6-M6×1.0	12	6	20	12.7	30	6.75	40	10	13	6.5	M6×1.0	8.96	9	11	1122	439	735	22
PHS 8-M8×1.25	16	8	24	15.875	36	9	48	12.5	16	7	M8×1.25	10.4	12	14	1633	735	1184	47
PHS 10EC-M10×1.25	20	10	26	19.05	43	11	56	15	19	8.5	M10×1.25*	12.9	14	17	2102	1020	1480	77
PHS 12EC-M12×1.25	22	12	32	22.225	50	12	66	17.5	22	10.5	M12×1.25*	15.4	16	19	2449	1367	1735	100
PHS 14EC-M14×1.5	25	14	36	25.4	57	13.5	75	20	25	10.5	M14×1.5*	16.9	19	22	3245	1735	2449	160
PHS 16EC-M16×1.5	28	16	40	28.575	64	15	84	22	27	11	M16×1.5*	19.4	21	24	3857	2204	2908	220
PHS 18-M18×1.5	32	18	46	31.75	71	16.5	94	25	31	13.5	M18×1.5	21.9	23	27	4694	2653	4337	320
PHS 20-M20×1.5	33	20	46	34.925	77	18	100	27.5	34	14	M20×1.5	24.4	25	30	5429	3214	4337	420
PHS 22-M22×1.5	43	22	50	38.1	84	20	109	30	37	12	M22×1.5	25.84	28	32	6100	4070	2290	475
PHS 25-M24×1.5	48	25	56	42.862	94	22	122	33.5	42	12	M24×1.5	29.6	31	36	7420	4950	2830	673
PHS 28-M27×2.0	53	28	67	47.625	110	26	143.5	40	50	15	M27×2.0	32.30	35	41	8870	5210	3240	875
PHS 30-M30×2.0	56	30	67	50.8	110	26	143.5	40	50	15	M30×2.0	34.81	37	41	11000	7370	3960	1050

\* Different from the thread pitch commonly available on the market.